

1831-15156

Check valve (36) and vacuum reservoir (37, except diesel)

Test B to E

Vacuum circuit 1, valve block (Y7)

Vacuum circuit 2, vacuum element for fresh/recirculated air flap (42)

Vacuum circuit 3, vacuum element for footwell flaps (39)

Vacuum circuit 4, vacuum element for center nozzle flap (40) for diverter air flap (41) and for defroster nozzle flaps (38)

Check for leaks, section A

Prepare

Check for leaks, section B with function selection

Check for leaks, section C with function selection

Check for leaks, section D with function selection and selector wheel MAX

Check for leaks, section E with function selection and selector wheel MIN

Permissible leakage rate

Permissible leakage rate per vacuum circuit (without vacuum reservoir)	30 mbar/min at 400 mbar vacuum
Permissible leakage rate of the check valve	50 mbar in 10 minutes with 300 mbar vacuum
Permissible leakage rate of the remaining components	20 mbar/min with 300 mbar vacuum

Special tool

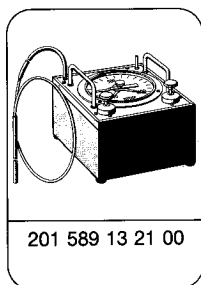

Self-made tool

1 plug	000 987 11 45
--------	---------------

Note

The vacuum test has been divided into 5 test circuits (A to E). If a certain fault is experienced (e.g. footwell flaps fail to open), the appropriate circuit can be checked first.

If a leak is suspected in the entire vacuum system for the automatic climate control, the test should commence with step "A" and continue with the other test circuits until the faulty vacuum circuit has been found.

A. Checking check valve (36) and vacuum reservoir (37) for leaks (except with diesel engine)

- 1 Loosen check valve holder.
- 2 Disconnect vacuum line medium green/yellow and on the gasoline models, additionally vacuum line red/green, from the check valve (36).
- 3 Connect tester (arrow) to the check valve. On the gasoline models, close the second connection with the dummy plug.
- 4 Evacuate with the tester and read the vacuum of the gauge. If the pressure rises on the pressure gauge, renew check valve.

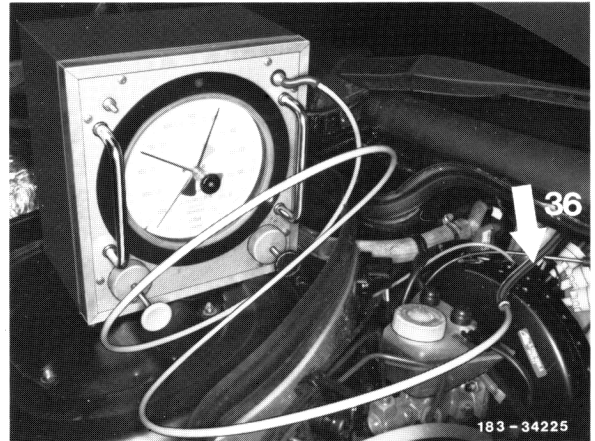

- 5 Pull off vacuum line red/grey from the check valve (36) and connect tester (arrow) to the vacuum line (not with the diesel).

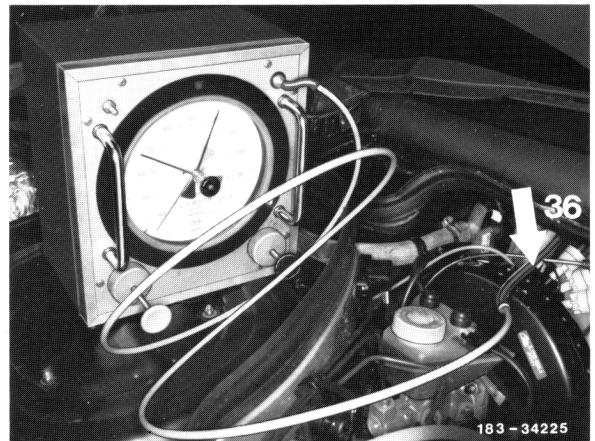

- 6 Evacuate with the tester and read the pressure of the gauge.
- 7 If the pressure gauge indication changes, remove the reservoir (37) and check for leaks, renew if required or renew vacuum line red/grey.

Arrangement, vacuum reservoir (37)
under front fender left (only gasoline
models)

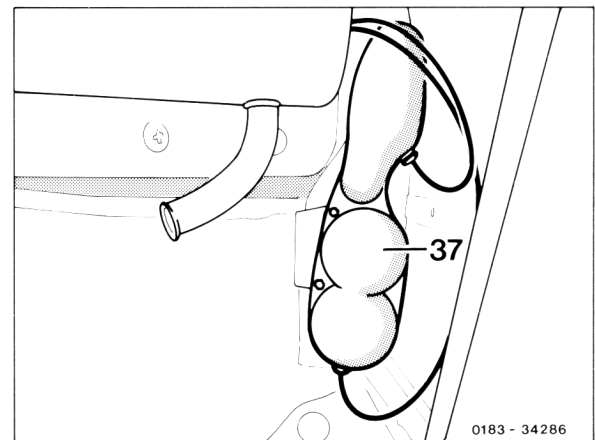

Preparing test B to E

- 1 Pull vacuum line medium green/yellow off check valve (36) and connect tester to the vacuum line.
- 2 Switch on ignition.

Note

The tester remains connected to the vacuum line medium green/yellow during the entire test.

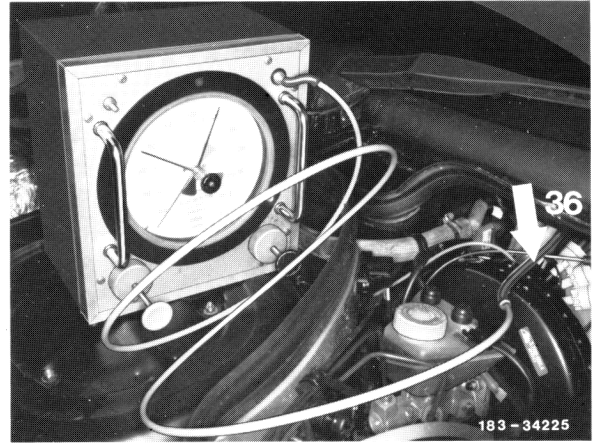

B. Checking vacuum circuit 1, valve block (Y7) for leaks

- 1 Press the function selection button  on the control unit.
- 2 Evacuate with the tester (approx. 400 mbar) and read off the pressure gauge.
- 3 If the indication on the pressure gauge changes, check switchover valve block (Y7) and vacuum line medium green/yellow, renew if required.

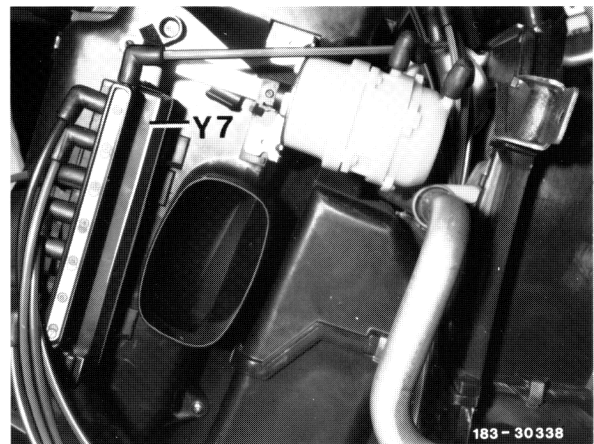

C. Checking vacuum circuit 2, vacuum elements for fresh/recirculated air flap (42) for leaks.

- 1 Press function selection button **0** on the control unit.
- 2 Evacuate with the tester (approx. 400 mbar) and read off the pressure gauge.
- 3 If the indication on the pressure gauge changes, individually check the vacuum elements (42), renew if required (83-665, section "E") or check vacuum lines medium green/light blue and dark red, renew if necessary.

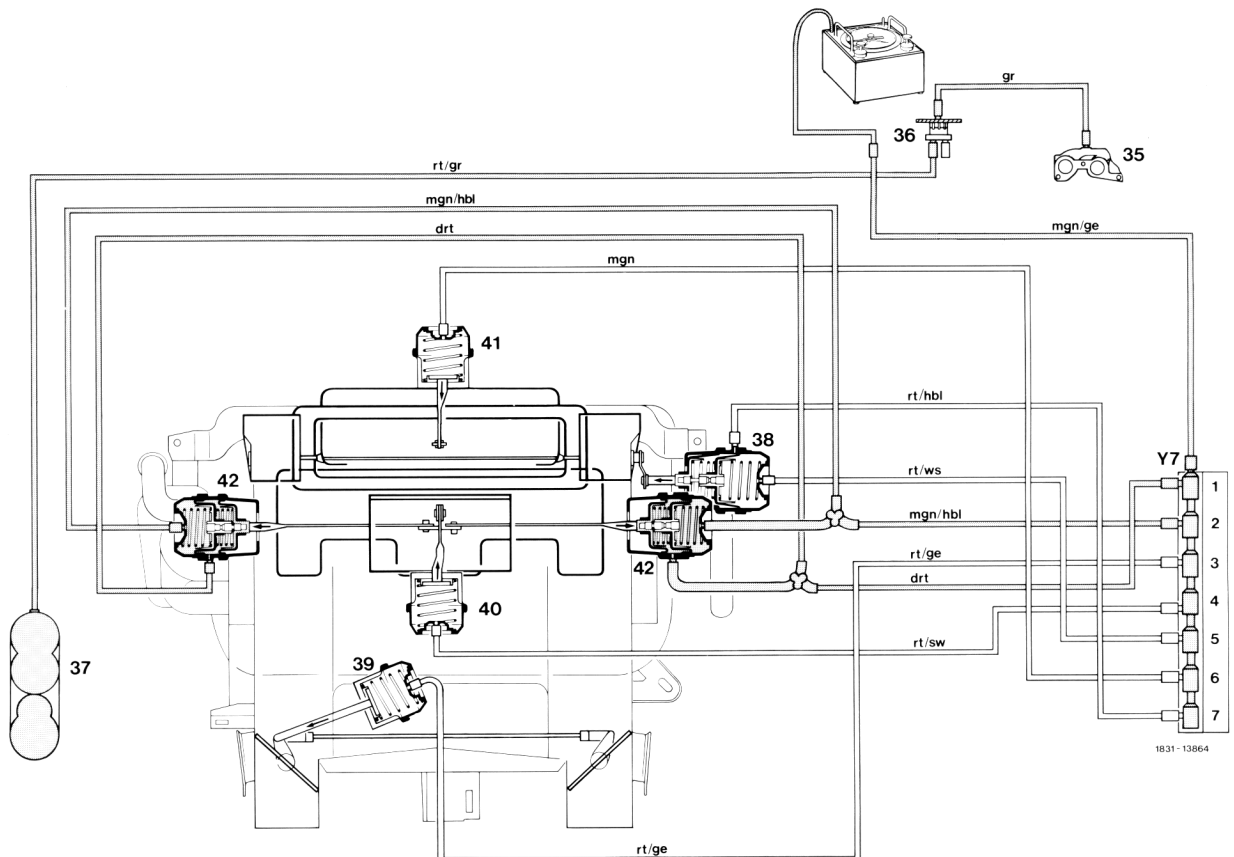
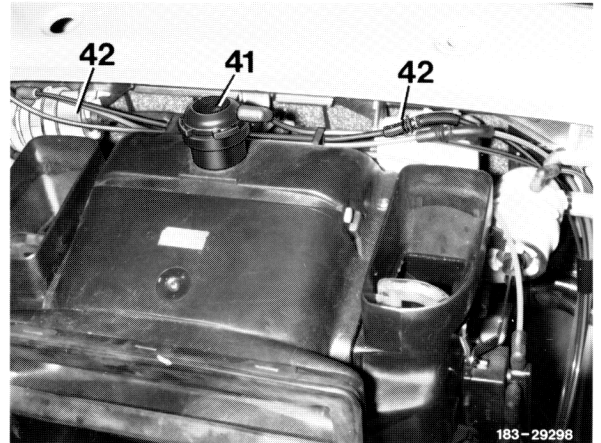

Vacuum circuit 2, function selection **0**

42 Vacuum element for fresh/recirculated air flap

D. Checking vacuum circuit 3, vacuum element for footwell flaps (39) for leaks

1 Press function selection button  on the control unit and engage temperature selector wheel in position "MAX".

2 Evacuate with the tester (approx. 400 mbar) and read off the pressure gauge.

3 If the indication on the pressure gauge changes, directly check the vacuum element (39), renew if required (83-665, section "A") or check vacuum line red/yellow, renew if required.

Note

Up to 08/86, two vacuum elements for footwell flaps have been installed.

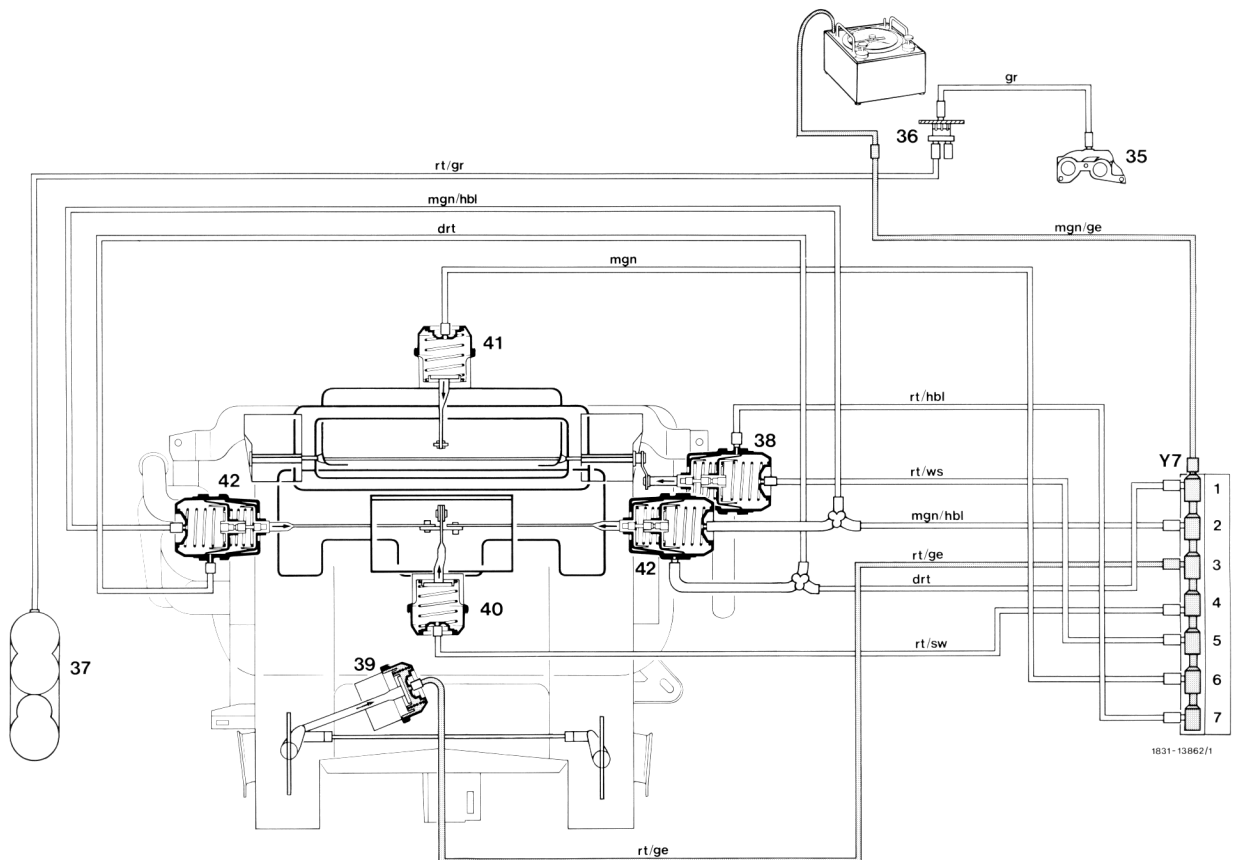
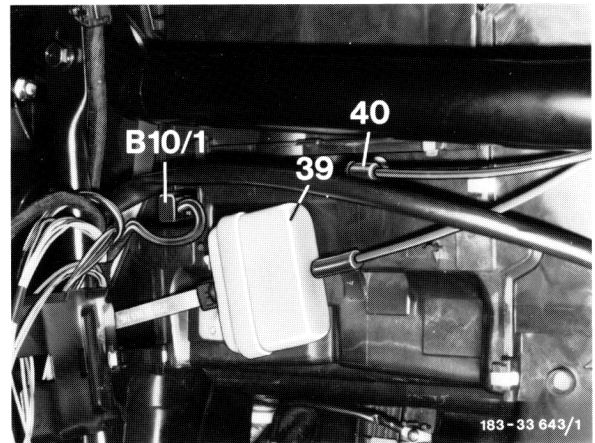

Vacuum circuit 3, function selection  and temperature selector wheel engaged in "MAX"

39 Vacuum element for footwell flaps

E. Checking vacuum circuit 4, vacuum elements for defroster nozzle flaps (38), center nozzle flap (40) and diverter air flap (41) for leaks

1 Press the function selection button  on the control unit and engage the temperature selector wheel in "MIN".

2 Evacuate with the tester (approx. 400 mbar) and read off pressure gauge.

3 If the pressure gauge indication changes, individually check the vacuum elements (38, 40 and 41), renew if required (83-665, section "A", "C" or "D") or check vacuum lines red/white, red/light blue, medium green and red/black, renew if required.

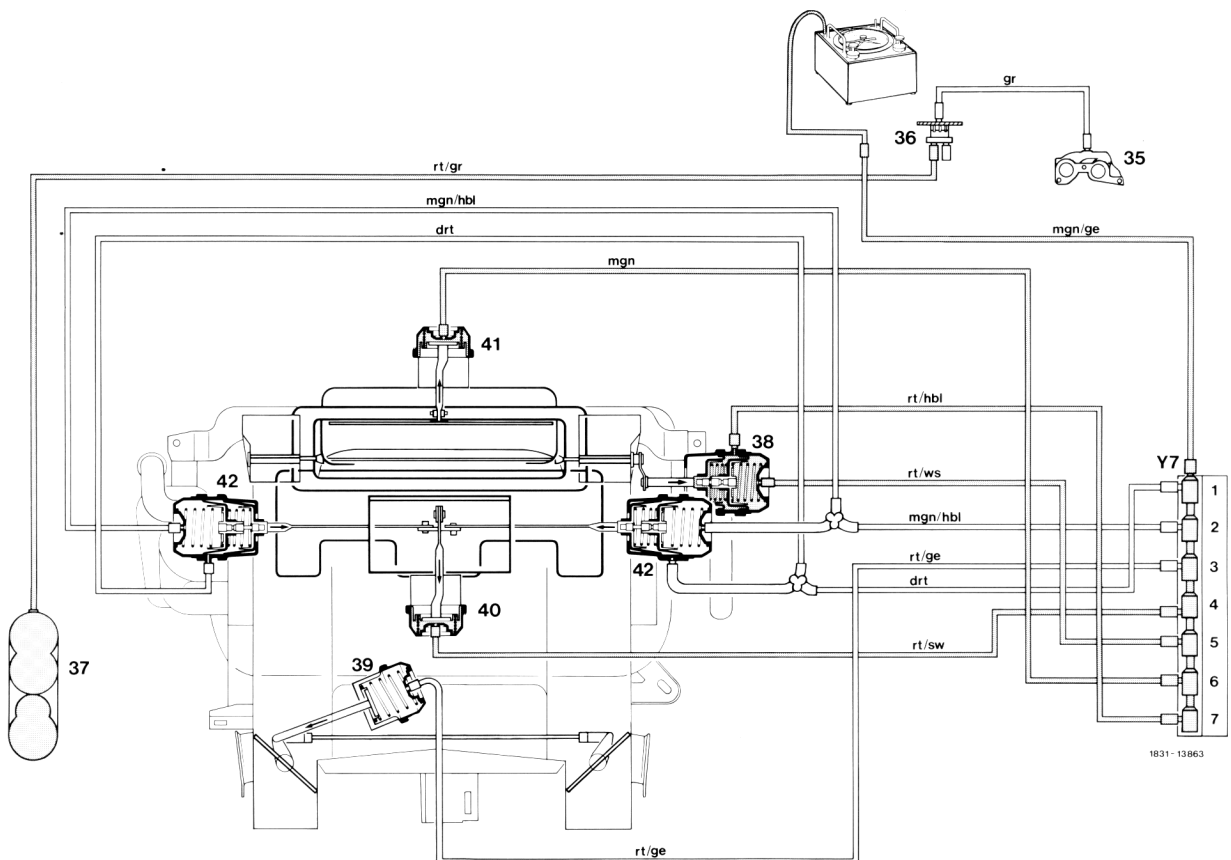
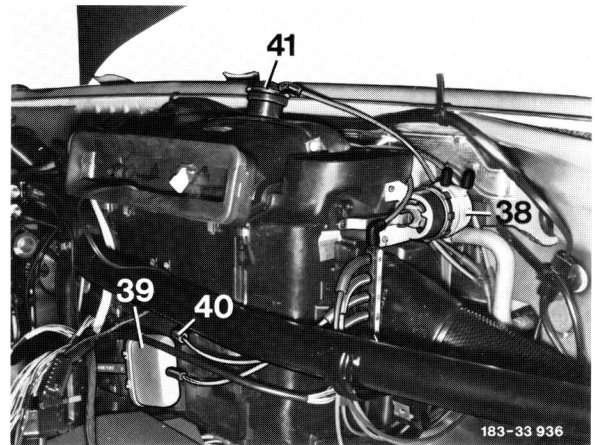

Vacuum circuit 4, function selection  and temperature selector wheel engaged in "MIN"

38 Vacuum element for defroster nozzle flap

40 Vacuum element for center nozzle flap

41 Vacuum element for diverter air flap