

03-3300 Removing and installing grooved ball bearing and end cover in crankshaft

Preceding work:
Transmission removed (26-020)
Clutch removed (25-050).

Operation no. of operation texts and work units or standard texts and flat rates

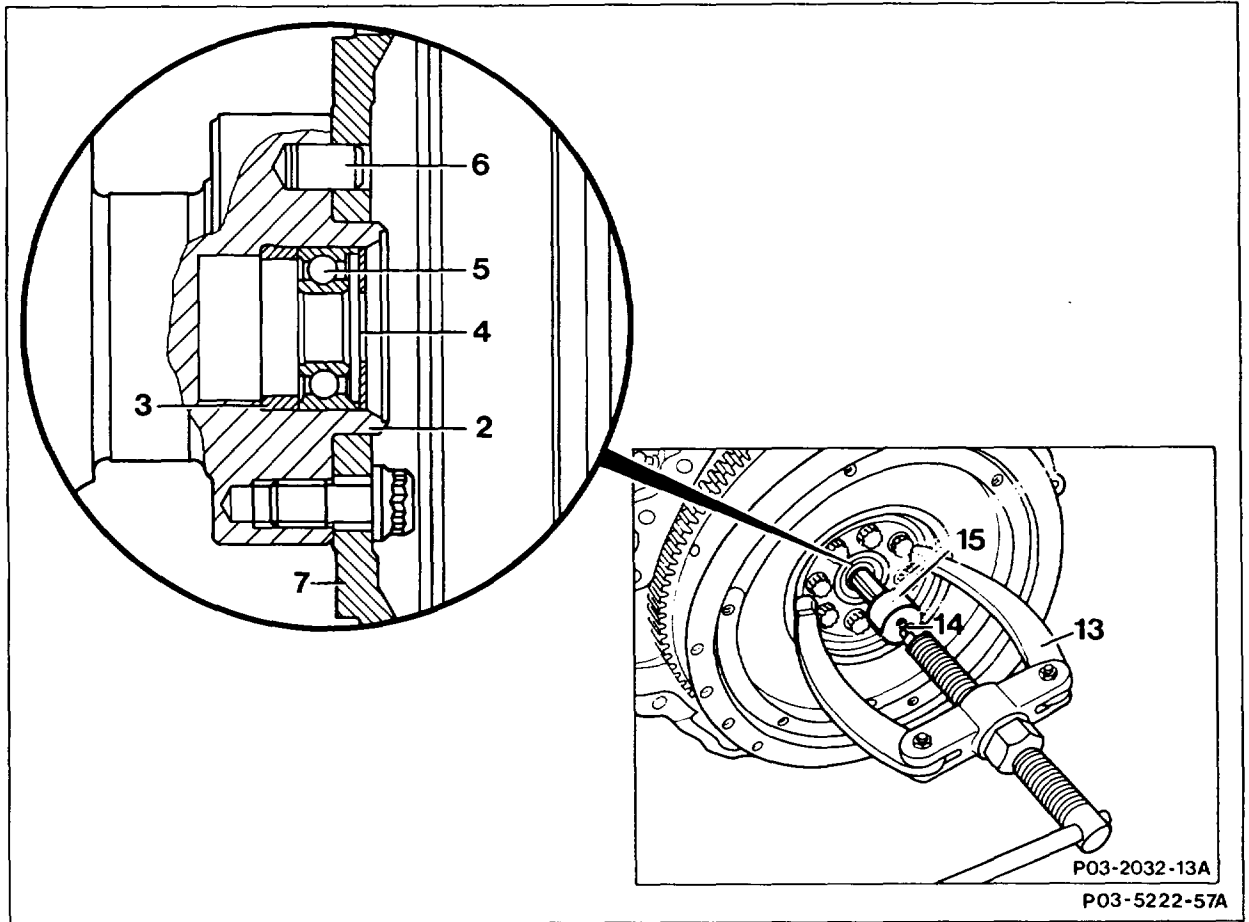

- 2 Crankshaft
- 3 Spacer ring
- 4 End cover

- 5 Grooved ball bearing
- 6 Dowel pin
- 7 Flywheel

Puller (13) 000 589 33 33 00 with insert (15)	
000 529 25 33 00	position on grooved ball bearing (5).
Nut (14)	turn, expand taper.
Grooved ball bearing (5) with end cover (4)	pull out.
New grooved ball bearing (5)	knock in with 35 mm dia. sleeve at outer race as far as stop.

Grooved ball bearing (5) must be seated firmly at outer race in crankshaft (2).

Note

If grooved ball bearing (5) is loose, stick it into the bearing bore of the crankshaft with Loctite 648, 003 989 32 17 10.

End cover (4) knock in flush.

Data in mm

Bearing bore in crankshaft	34.99 – 35.01
----------------------------	---------------

Special tools

