

14-0490 Converting USA tourist vehicles with catalytic converter

Tourist vehicles have been supplied since 05/88 with a catalytic converter. The difference to the USA version consists of the ignition system and the information plate for the emissions control system on the radiator cross bar.

The tourist vehicles must be converted as follows in the VPCs:

- A. Replacing reference resistor/resistance coupling of ignition system
- B. Replacing spark plugs
- C. Testing exhaust system and oxygen sensor for lead residues with Plumbtesmo test paper
- D. Replacing information plate for emissions control system on radiator cross bar
- E. Function test

A. Replacing reference resistor of ignition system

The reference resistor (R16/1) is incorporated in the wiring harness.

Untie wiring harness and install reference resistor part no. 000 540 24 81 (up to 09/89). Attach reference resistor separately.

Model 107

Location of reference resistor (R16/1)

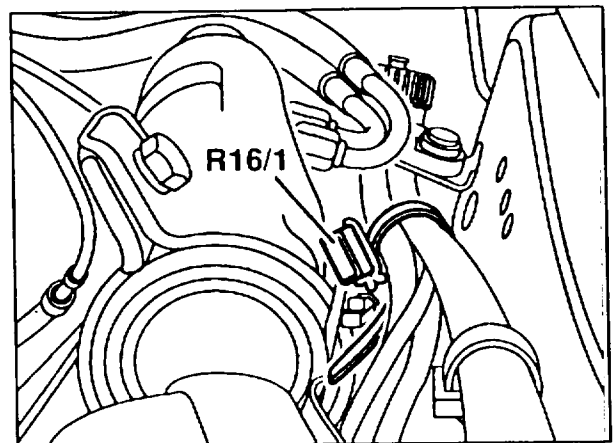

115-31620

Model 124

Location of reference resistor (R16/1)

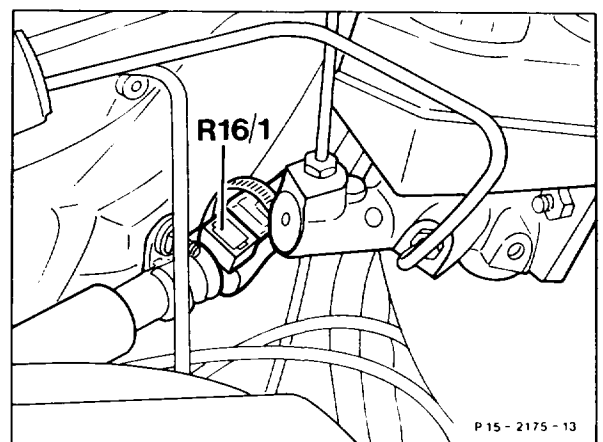

P 15 - 2175 - 13

Model 126
 Location of reference resistor (R16/1)

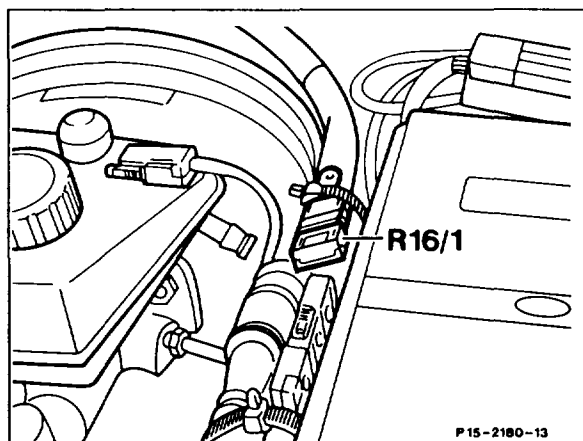

On model 201.029, remove and install air cleaner.

Model 201
 Location of reference resistor (R16/1)

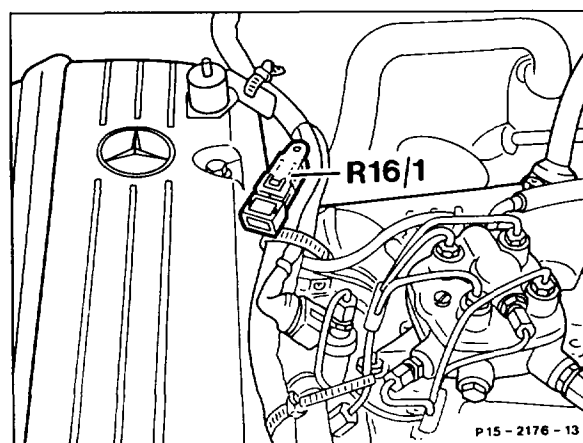

B. Replacing spark plugs

Install spark plugs as stated in the table.

Tightening torque with tapered seat 10 – 20 Nm

Permissible top speed max. 160 km/h (100 mph)

Table of spark plugs

	Engine 103
BERU	14K-9DU or 14K-9DUO
BOSCH	H9DC or H9DCO
CHAMPION	S12YC or S12YCC

C. Testing exhaust system and oxygen sensor for lead residues with Plumbtesmo test paper

Fuels containing lead impair the operation of the oxygen sensor and the catalytic converters. For this reason, it is necessary to verify that the vehicle has been operated with unleaded fuel. Adopt the following procedure in order to perform this check:

- Engine switched off, exhaust tailpipe and oxygen sensor must be warm (not glowing hot).
Remove oxygen sensor and install (see 07.3-5303).
- Moisten Plumbtesmo test paper with 2 drops of distilled water and press with your thumb against the inner wall of the exhaust tailpipe for about 2 minutes or place test paper around the protective grille of the oxygen sensor and likewise press for about 2 minutes.
- Remove test paper and assess (see table).

Color	Analysis
unchanged	no lead residues, test negative
pink	very slight lead residues, test negative (unleaded fuels may contain up to 0.015 g lead per liter); no impairment of operation
red	lead residues too high, test positive; test must be repeated

Note

As the lead test is very sensitive, it is very important to ensure that positive indications of lead do not occur erroneously by entraining traces of lead. For this reason, after each positive test, it is recommended to wash your hands or to wear disposable gloves. Test papers which have dropped onto the ground must not be re-used as the dust may contain traces of lead.

If the test paper again colors red after repeating the test, the oxygen sensor or the catalytic converter system must be replaced.

D. Replacing information plate for emissions control system on radiator cross bar

Pull off information plate "CATALYST APPROVED FOR IMPORT" on radiator cross bar. Clean contact surface. Affix information plate for emissions control system "CATALYST".

E. Function test

Note

If the test data are not achieved by adjustment, the test procedure must be interrupted. Rectify any faults as specified in the repair instructions.

Test procedure:

Connect testers for oil temperature, engine speed, ignition angle and lambda control.

Warm up vehicle on the roller dynamometer at part load in position D or 3rd gear (60 km/h, about 25 kW). Engine oil temperature about 80 °C.

- 1 Check that the accelerator control linkage operates freely and is correctly set.

- 2 Test the air injection system:
Start engine and at the same time observe the air pump.
The air pump must run briefly when the engine is started.

- 3 Test exhaust gas recirculation system:
Connect vacuum tester with Y union to the exhaust gas recirculation valve. Increase engine speed to 3200 rpm.
Specification: > 400 mbar.

- 4 Test ignition angle:
Engine idling,
specification with vacuum: 7 – 11° before TDC.



- 5 Test idle speed:
AC off, parking brake applied.
Specification for engine 103.94 position P/N: 650 – 750 rpm
Specification for engine 103.98 position P/N: 600 – 700 rpm
Specification position D: 550 – 650 rpm

- 6 Test regeneration valve:
Disconnect pipe from the activated charcoal filter at the regeneration valve and connect vacuum tester to regeneration valve.
Specification at 2500 rpm: > 400 mbar.

- 7 Test lambda control (see 07.3–1100):

- 8 Test Check-Engine display (n.a. as of model year 1992 on vehicles in Federal version):
Switch off engine, disconnect testers.
Switch on ignition → Check-Engine lamp on
Start engine → Check-Engine lamp off

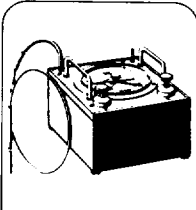
Special tools

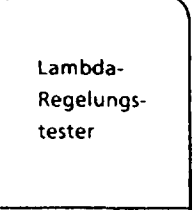
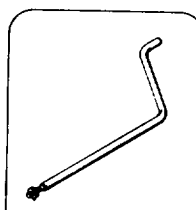
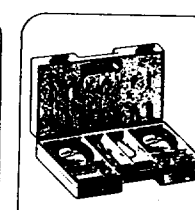
				
201 589 13 21 00 00 42 80	124 589 07 21 00 18	Lambda- Regelungs- tester 909 589 00 21 00	123 589 09 63 00 03	201 589 00 99 00 15 54

Commercially available testers (see Workshop Equipment Manual)

Designation

Engine tester (rpm, dwell angle, ignition angle)	e.g. Bosch, MOT 001.03 Sun, Hermann
Plumbtesmo test paper	available from the trade