

49-0300 Converting vehicle with catalytic converter

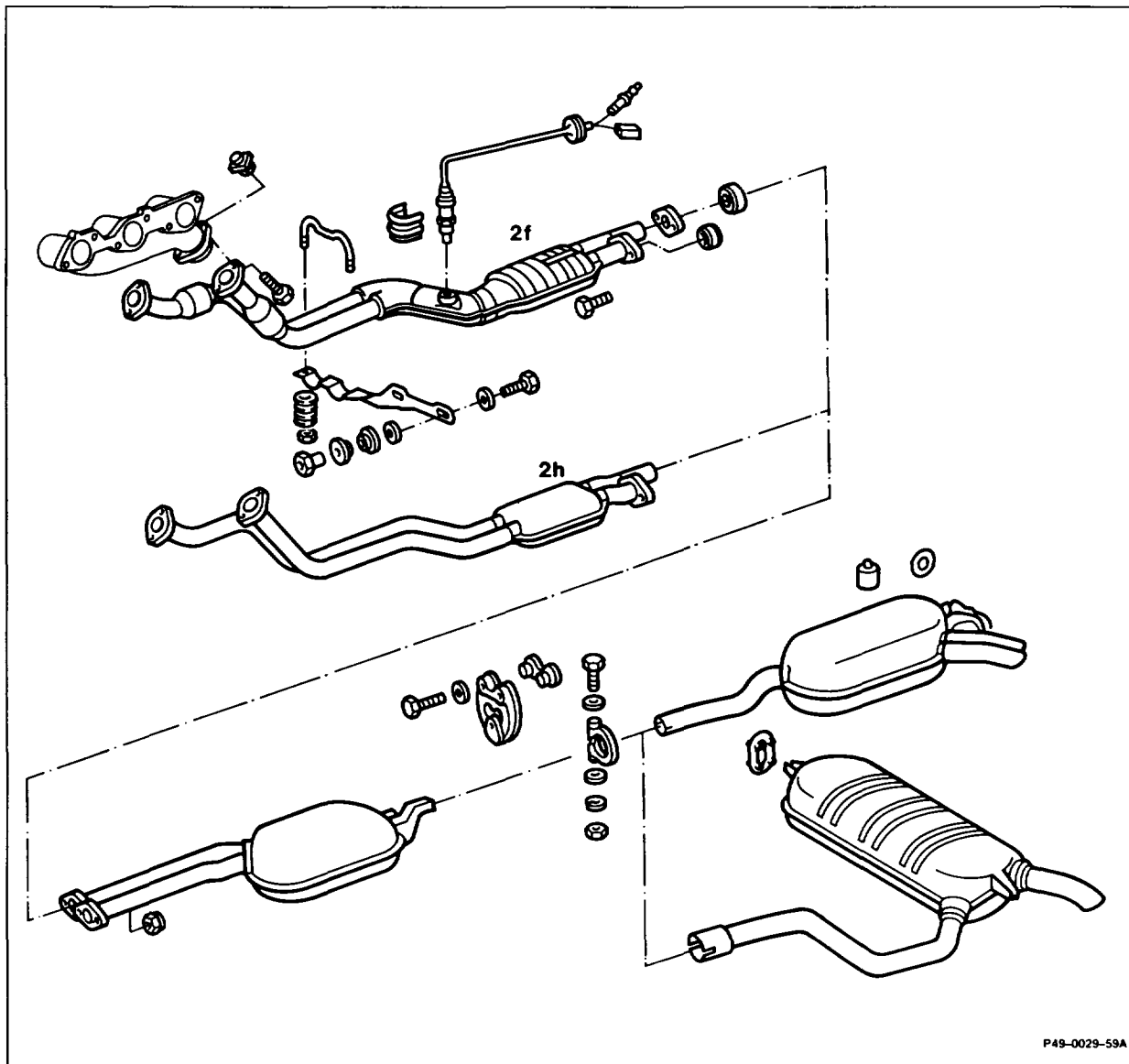

Shown on model 124

Exhaust system remove (49-7000).
 In place of rubber grommet of connection
 cable of oxygen sensor insert a dummy plug.

Note

Not applicable to vehicles without closed-loop catalytic converter.

Front exhaust system (2f) exchange with version without catalytic
 converter (2h).
 Exhaust system install (49-7000).
 Resistance trimming plug for EZL ignition
 control unit and KE control unit exchange (MF system).

Note

New resistance trimming plug for KE control unit must be sealed.

Engine data plate replace.
 Engine as per data plate set: ignition timing point, CO level, idle speed
 (07.3-2053).
 Affix ASU disc to front license plate and issue
 test certificate.
 Guide funnel in filler neck remove (47-4100, section A).
 Fuel information plate for unleaded fuel remove.

Note

On vehicles with multi-functional mixture preparation and ignition system (MF), affix fuel information plate 124 583 36 21 A.

Commercially available tools and testers (see Workshop Equipment Manual)

Designation	e.g. Make, order no.
Engine tester with oscilloscope	Bosch, MOT 002.02
CO analyzer	

Parts

Designation	Engine	Part no.
Sealing wire	-	001 367 00 00 15
Seal	-	000 988 09 70
Engine data plate	103.940/941/982 without KAT	124 584 57 21
	103.983/981/982 without KAT	124 584 60 21

Vehicles fitted with a catalytic converter must not be operated with leaded fuel.

For this reason, the catalytic converter and other components must be removed and the engine setting also altered for traveling in countries in which unleaded fuel is either not available or not throughout the country.

Basically, such customers who wish a conversion should be advised to consider a cost/benefit analysis.

Apart from the purely technical conversion work, a point to consider is that a vehicle registered in the Federal Republic of Germany must be presented to the Technical Inspection Centre for Motor Vehicles following the conversion and this may affect the reduction or the temporary exemption from vehicle license duty.

If the converted vehicle has to be presented to a Technical Inspection Centre for Motor Vehicles, a confirmation relating to the applicable technical data of the vehicle following conversion is essential.

This confirmation, relating to the individual vehicle, must be requested in good time from our department EP/BZT. Such an application should be submitted together with a copy of the vehicle registration documents.

Note

In the event that a customer wishes to have his vehicle equipped again with a catalytic converter at a later date, the removed parts should be made available to him.

We should like to point out that the re-installation must be approved by a Technical Inspection Centre for Motor Vehicles.

In this connection also, an individual confirmation should be requested in good time from our department EP/BZT, enclosing a copy of the vehicle registration documents.