

All engines

- Switch off ignition.
- Mark poly-V-belt with chalk at an accessible point (arrow).

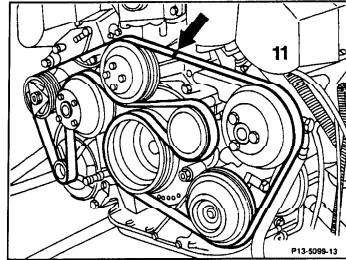

Models except 140

- On all models except 140, connect special tool 001 589 76 21 00 or remote starter switch and turn crankshaft in steps.

Model 140

- On model 140, use ignition key to turn engine crankshaft in steps. Interrupt fuel supply. This results in the setting of Diagnostic Trouble Codes which must then be erased from the following control modules:
LH-SFI control module.
Ignition control module.
Diagnostic module, if equipped.
(Refer to Diagnostic Manual, Engines, Vol. 2, 3).
- On all models, check belt for damage (see illustrations). Replace the belt if any of the damage illustrated is apparent.

Special tools

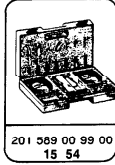

WARNING!

Because of the high ignition voltage on gasoline engines, it is dangerous to touch ignition components (ignition coil, ignition cables, spark plug connector, module push connectors) when

- the engine is running,
- the engine is being started,
- the key is in position 2 while the engine is being turned manually.



Gefährliche Hochspannung!
Vorsicht bei Arbeiten an der Zündanlage

Danger! High voltage
Observe caution when working on the ignition system

Danger! Haute tension
Attention lors de travaux au système d'allumage

P01-5329-13

A. Model 124 with engine 104

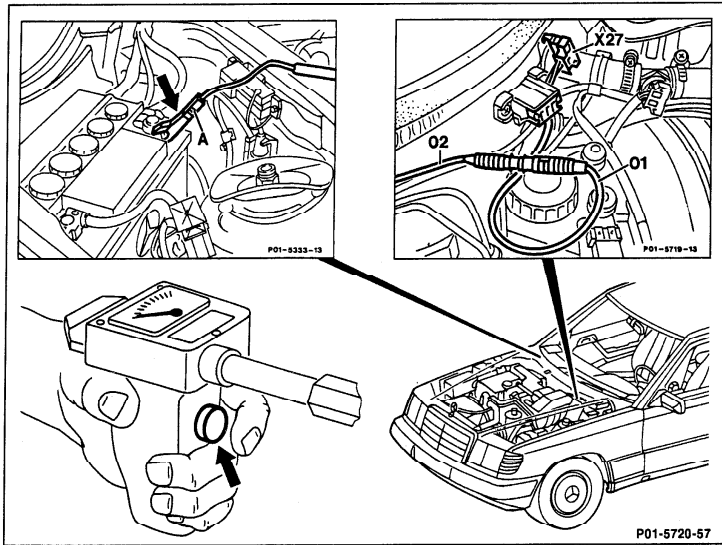

- Switch off ignition.
- Connect clamp (arrow) of compression tester 001 589 77 21 00 to battery positive terminal.
- Pull off plug of connector (X27) and connect to adapter cable (01) 124 589 36 63 00.
- Connect adapter cable (01) to cable (02) of compression tester.
- With parking brake applied and transmission in Park position, turn crankshaft in steps by pressing button (arrow) on tester.

⚠ NOTE:

Do not turn engine crankshaft by using ignition key.

Model 124 with engine 119.974

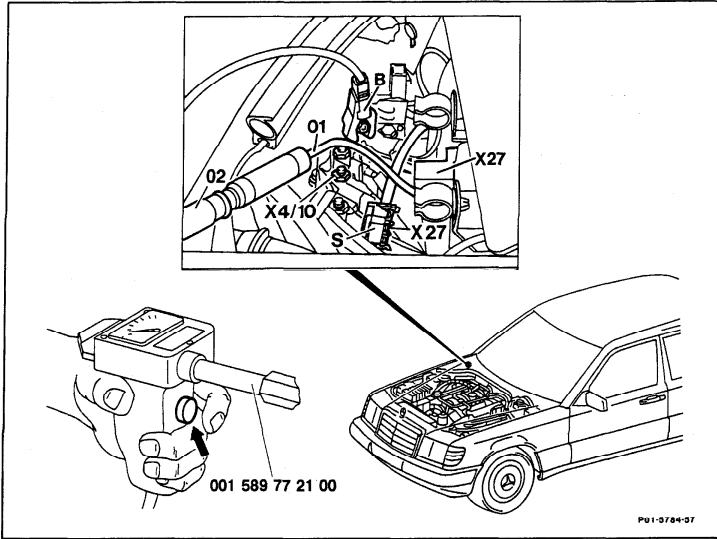

- Switch off ignition. Remove cover from component compartment wall.
- Pull off plug (S) of connector (X27) and connect to adapter cable (01) 124 589 36 63 00. Connect adapter cable (01) to cable (02) of compression tester.
- Open cover of connector (X4/10). Connect clamp (B) of compression tester to connector (X4/10).
- With parking brake applied and throttle is idle speed position, turn crankshaft in steps by pressing button (arrow) on tester.

NOTE:

Do not turn engine crankshaft by using ignition key.

Model 124 with engine 119.975

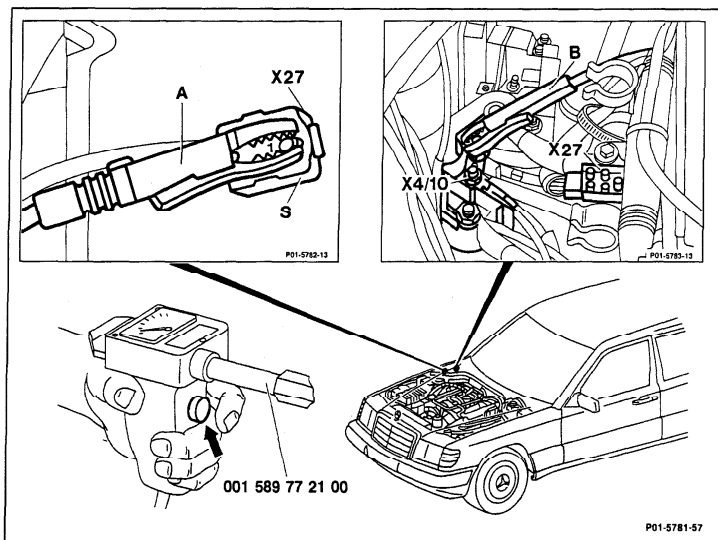

- Switch off ignition. Remove cover from component compartment wall.
- Pull off plug (S) of connector (X27). Connect clamp (A) of compression tester to pin 1 of plug (S).
- Open cover of connector (X4/10). Connect clamp (B) of compression tester to connector (X4/10).
- With parking brake applied and throttle in idle speed position, turn crankshaft in steps by pressing button (arrow) on tester.

NOTE:

Do not turn engine crankshaft by using ignition key.

Model 129 with engine 120

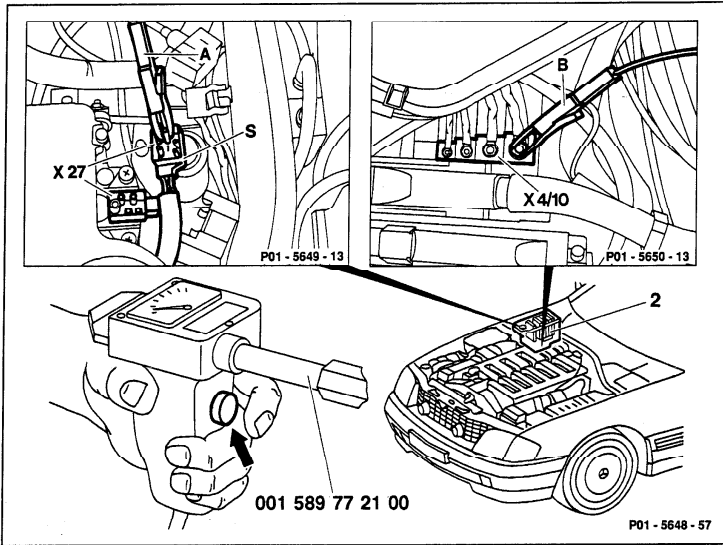

- Switch off ignition. Remove cover from component compartment wall.
- Release latch of connector (X27). Connect clamp (A) of compression tester to pin 1 of plug (S).
- Open cover of connector (X4/10). Connect clamp (B) of compression tester to connector (X4/10).
- With parking brake applied and throttle is idle speed position, turn crankshaft in steps by pressing button (arrow) on tester.

⚠ NOTE:

Do not turn engine crankshaft by using ignition key.

Model 202 with engines 104, 111

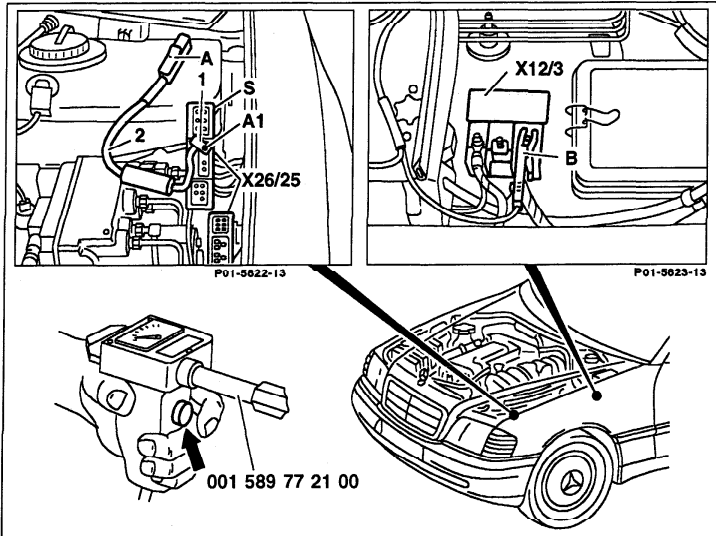

- Switch off ignition.
- Remove cover from connector (X26/25). Pull latch of connector (X26/25) forward.
- Unplug plug (S) of connector (X26/25). Connect adapter cable (2) to pin (A1).
- Connect clamp (A) of compression tester to adapter cable (2).
- Open cover of connector (X12/3). Connect clamp (B) of compression tester to connector (X12/3, circuit 30).

- With parking brake applied and throttle is idle speed position, turn crankshaft in steps by pressing button (arrow) on tester.

⚠ NOTE:

Do not turn engine crankshaft by using ignition key.

B. Model 140 with engines 104, 119, 120

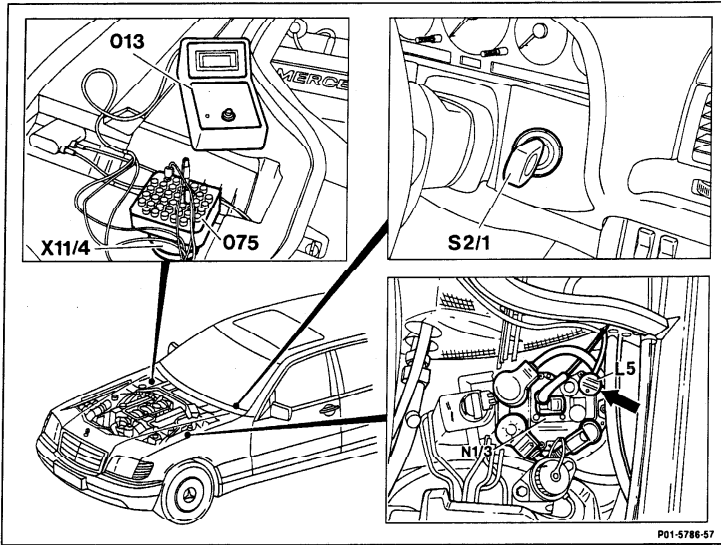

013 Impulse counter scan tool
 075 Impulse counter scan tool adapter
 X11/4 Data link connector (38-pole)

- Remove cover(s) from ignition control module(s).
- Interrupt fuel supply by disconnecting crankshaft position sensor(s) (L5) (arrow) from ignition control module(s).
- With parking brake applied and throttle is idle speed position, turn crankshaft in steps by turning ignition key.
- Read out and erase DTC memory. (Refer to Diagnostic Manual, Engines, Vol. 2, 3).

C. Damage patterns

- Rubber lumps in rib base (C).
- Dirt or stone deposits (D).

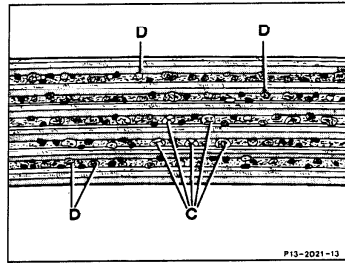

- Flank wear (F, ribs are pointed - trapezoidal when new, E).
- Strand showing through rib base (G, brighter spots).

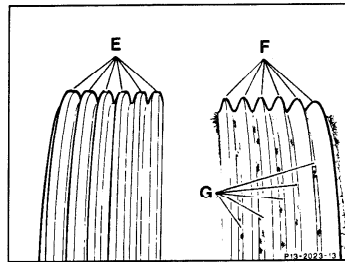

- Transverse cracks (H) in several ribs.

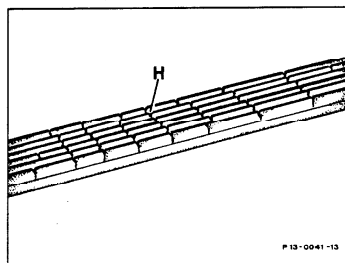

- Transverse cracks in ribs (H) and/or rib chunking (J).

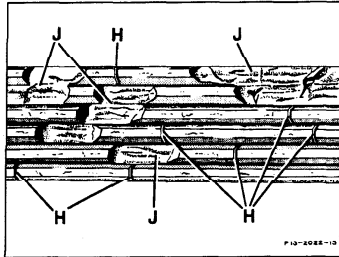

- Strand (K) pulled out laterally or outer strands frayed (L).

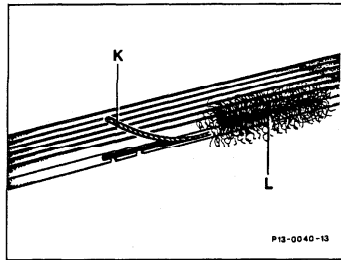

- Transverse cracks (M) on back.

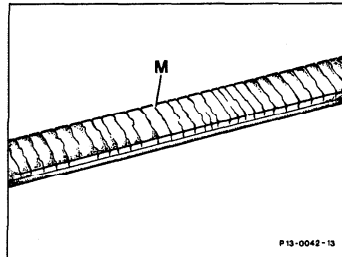

- Rib separated from belt (arrow).

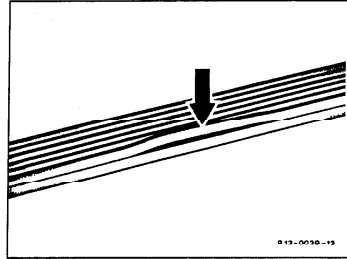

Replacing poly-V-belt

Special tools

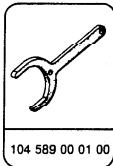
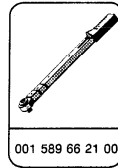
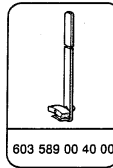
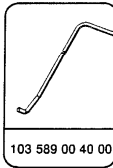
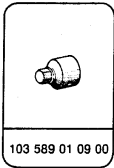

Engine 104

- Pull out locking pin (1) on fan cover.
- Turn ring (2) to the left and remove.

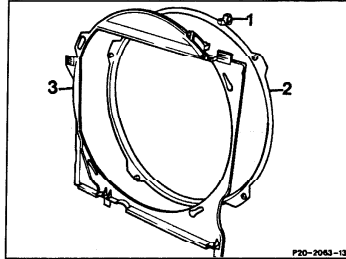

- Loosen screw (16) for approx. 1/4 to 1/2 turn.
- Loosen tensioning unit with tensioning nut (5) (turn **counterclockwise**) until the belt can be removed.
- Check pulley profiles and tensioning device for damage and contamination and replace, if required (e.g. worn out bearing points of tensioning device, dents in pulley etc.).

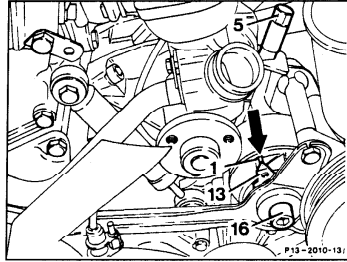

Install poly-V-belt:

- Starting in numerical sequence of belt routing diagrams at tensioning pulley (1).

Note: Do not use belt wax or similar products.

- Set pointer (13) of tensioning unit to mark 2.
- Turn tensioning nut (5) downwards until adjusting pointer (13) is in alignment with mark 1 (arrow).
- Check seat of belt on pulleys.
- Tighten screw (16) to 75 Nm.
- Install ring of fan cover in reverse sequence.

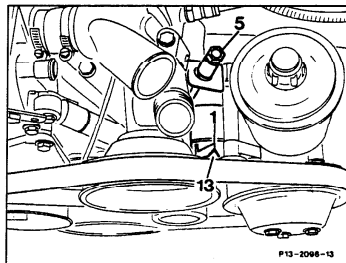

Engine 104 models 124, 129, 140

Belt routing diagram vehicles with air pump and with air conditioning compressor,

- 1 Tensioning pulley
- 2 Crankshaft
- 3 Air conditioning compressor
- 5 Fan
- 7 Air pump
- 8 Generator
- 9 Guide pulley, upper
- 10 Power steering pump
- 11 Coolant pump

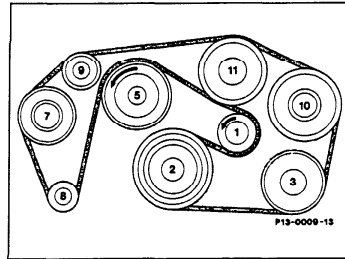

Engine 111

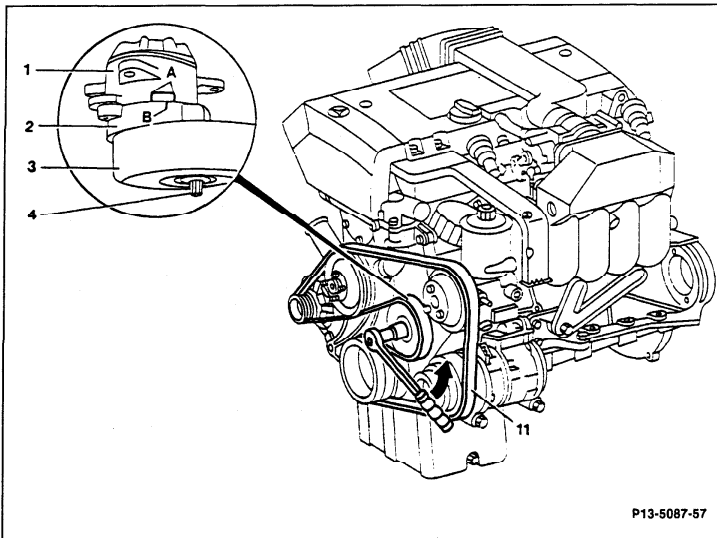

- Pivot tensioning arm (2) with tensioning roller (3) counter clockwise by placing wrench with suitable socket on Torx bolt (4, external Torx E10).
- Remove poly-V-belt (11).
- Check pulleys for wear or damage. Install new poly-V-belt (11) according to belt routing diagram numbering sequence.
- Check that belt is seated properly on pulleys.

Note:

The position mark (B) should be within the range (A) with the correct belt length and the tensioner functioning properly.

**Engine 111
Belt routing diagram**

1. Tensioning pulley
2. Crankshaft
3. A/C compressor
4. Generator
5. Fan
6. Coolant pump

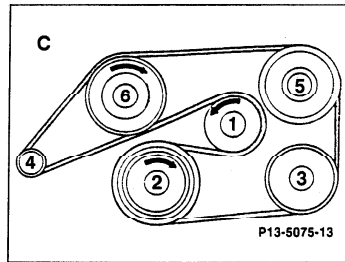

Engine 119

- Pull locking pin from fan cover.
- Turn ring to the left and remove.
- Loosen screw (16) approx. 1/4 to 1/2 turn.
- Loosen tensioning device with tensioning nut (12) (turning counterclockwise) until the belt can be removed.
- Check pulley profiles and tensioning device for damage and contamination and replace, if required (e.g. worn out bearing points of tensioning device, dents in pulleys etc.).

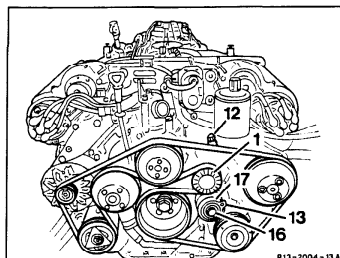

Installing poly-V-belt:

- In numerical sequence of belt routing diagrams, start with tensioning pulley (1).

Note:

Do not use belt wax or similar products.

- Set pointer (13) of tensioning device to mark 1.

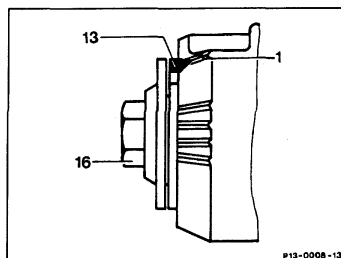

- Turn tensioning nut (12) clockwise until pointer (13) is in position 2.
- Check that belt is seated correctly on pulleys.
- Torque screw (16) to 100 Nm.
- Install fan cover in reverse order.

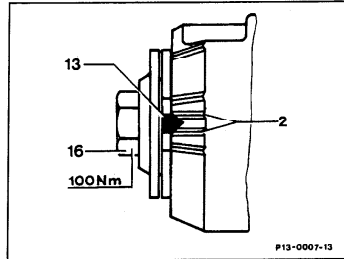

Engine 119.970 model 140.051
 119.971 model 140.042
 119.972 model 129.067
 119.974 model 124.036
 119.975 model 124.034

Belt routing diagram

1. Tensioning pulley
2. Crankshaft
3. A/C compressor
5. Fan
7. Air pump
8. Generator
10. Power steering pump
11. Coolant pump

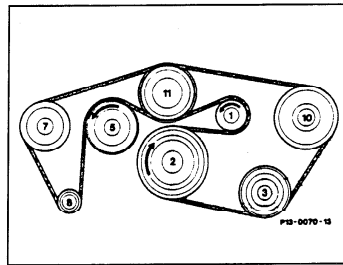

Engine 120

- Remove cooling fan (job no. 20-3129)
- Using 15 mm wrench, swing tensioning roller (1) aside in direction of arrow up to stop and no further so that belt can be removed. Check pulley profiles and tensioning device for damage and contamination and replace, if required (e.g. worn out bearing points of tensioning device, dents in pulleys etc.)

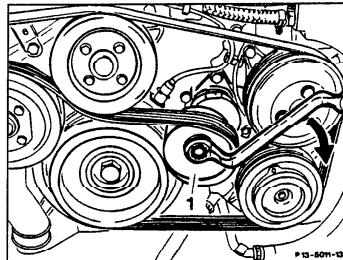

Installing poly-V-belt:

- In numerical sequence of belt routing diagrams, start with tensioning pulley (1).

Note:

Do not use belt wax or similar products.

- Pretension tensioning pulley (1) and install belt over pulley (1). Check that belt is seated correctly.

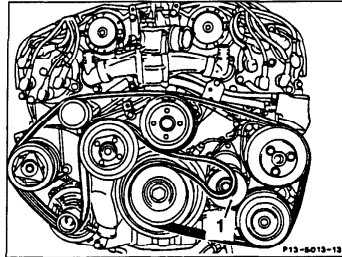

Note:

When the belt length and tension are correct the positioning mark (P) will be within range (A).

- Reverse procedure to install.

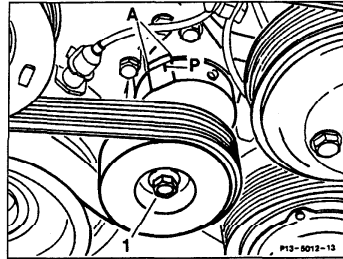

Engine 120

Belt routing diagram

1. Tensioning pulley
2. Crankshaft
3. A/C compressor
5. Fan
7. Air pump
8. Generator
9. Guide pulley, upper
10. Power steering pump
11. Coolant pump

