

## 15-5032 Removing and installing alternator

### Preceding work:

Poly V-belt removed (13-342)

Engine compartment panel removed (61-0105), engines 104,  
111, 119.974/975

Front noise encapsulation removed (94-5310)

Operation no. of operation texts and work units  
or standard texts and flat rates:

### A. Engines 102, 103, 104, 111, 601, 602, 603, 605, 606

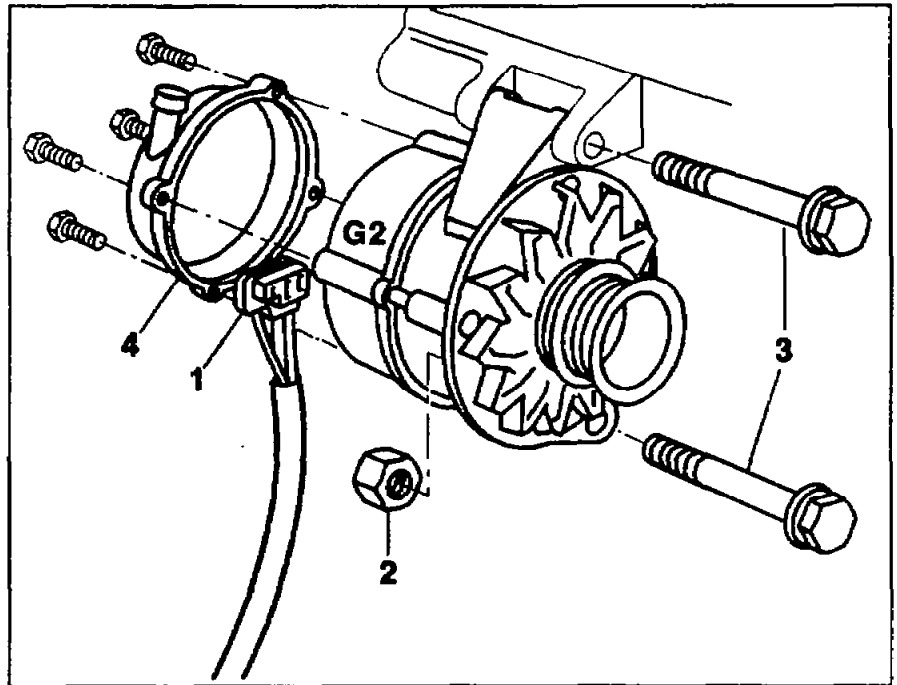

Bowl-type alternator

P15-5257-35

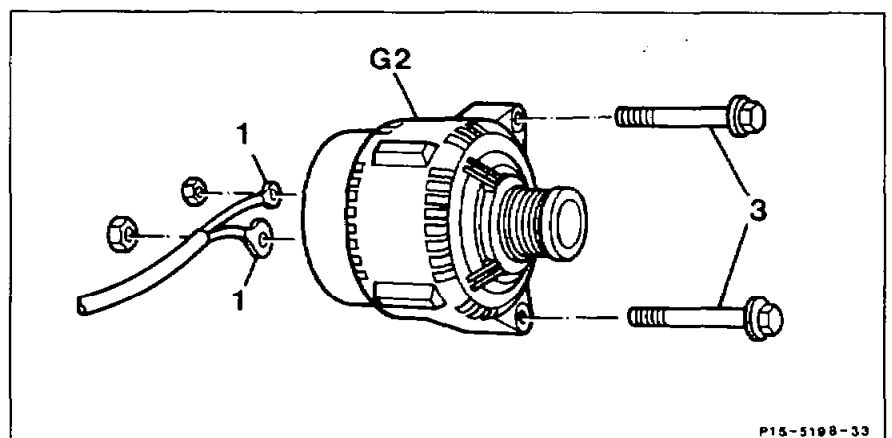

Compact alternator

P15-5198-33

Battery ground cable . . . . .	disconnect, connect.
Air intake cover (4) . . . . .	remove, if required, reinstall.
Electrical connection or connections (1) on alternator (G2) . . . . .	disconnect, reconnect.
Hex. nut (2) . . . . .	screw off, screw on (if present).
Hex. head bolts (3) . . . . .	screw out, screw in.
<b>Engines 102, 103</b>	
Alternator (G2) . . . . .	<i>remove upward, install from above.</i>
<b>Engine 104, 111, 601, 602, 603, 605, 606</b>	
Alternator (G2) . . . . .	remove downward, install from below.

## B. Engines 119.974/975

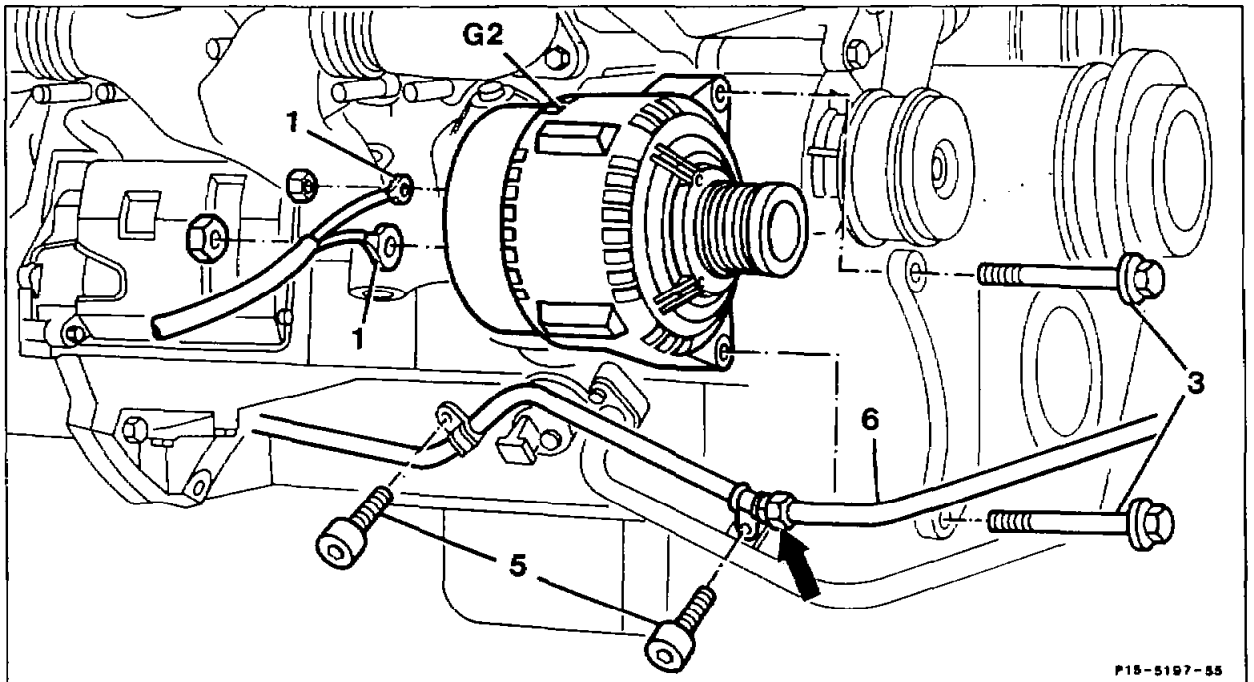

Ground cable at battery .....	disconnect, connect.
Electrical connections (1) .....	disconnect, connect.
Hex. head bolts (3) .....	screw out, screw in.



When installing alternator (G2) first start the upper hex. head bolt.

Torsion bar bracket on left and right frame side members .....	remove, install. Tightening torque 60 Nm.
--	---

### Engine 119.974

Bolts (5) for transmission oil line (6) .....	remove, install.
Transmission oil line (6) .....	disconnect at threaded fitting (arrow), reconnect.



Catch automatic transmission fluid!

### All engines

Alternator (G2) .....	remove downward, install from below.
-----------------------	--------------------------------------

### Engine 119.974

After installation check automatic transmission fluid level .....	See Maintenance Manual, Volume II, operation item (2710).
---	---