

35-130 Removal and installation of rear axle shaft flange with angular ball bearing

Preceding work:
Remove, install wheels 40-110.

Operation no. of operation texts and work units
or standard texts and flat rates:
35-0260, 35-0261, 35-0262

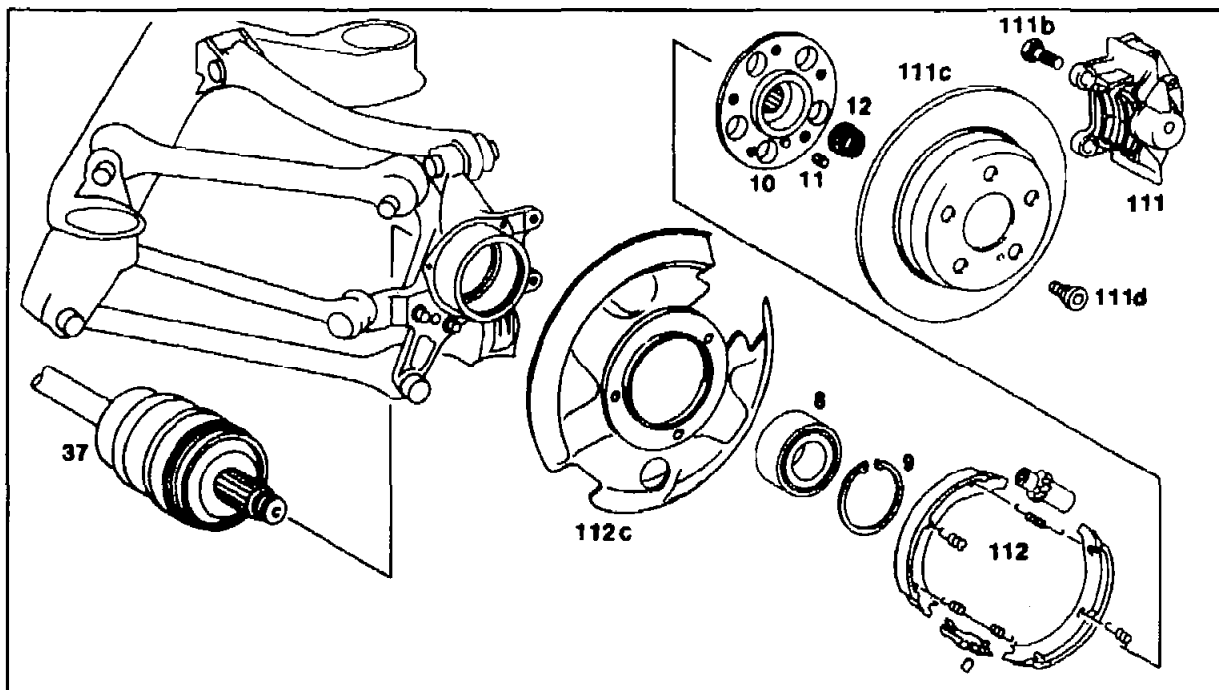

P35-0029-55

- | | |
|-----------------------------------|---|
| <p>Rear axle shaft (37)</p> | <p>Remove, install (35-620, number 1). Unscrew, replace, screw on and fasten twelve-point collar nut (12). Lubricate thread and head bearing surface. Tightening torque 200 – 240 Nm. Use extractor/pulling-in equipment 140 589 03 61 00 to remove and press in rear axle shaft if it seats tightly. Torque wrench 001 589 74 21 00, socket wrench insert 30 mm 126 589 02 09 00 (number 2).</p> |
| <p>Brake caliper (111)</p> | <p>Remove, install (42-120, number 3). Replace self-locking hexagon bolts (111b). Torque wrench 001 589 66 21 00. Assemble brake hose or, in the case of vehicles with ASR, electric cable of brake lining wear indicator without twisting.</p> |

Brake disk (111c)	remove, install (42-228). Replace self-locking hexagon socket bolt (111d) (number 4).
Brake shoes of parking brake (112)	remove, install (42-530, number 5).
Rear axle shaft flange (10)	using extractor/pulling-in equipment 140 589 03 61 00 and setbolt section 19, pull out from angular-contact ball bearing or angular-contact roller bearing (8). Using extractor/pulling-in equipment 124 589 05 43 00 pull in rear axle shaft flange (number 6).
Circlip (9)	remove, install. Check for correct seating in wheel carrier. Circlip pliers 126 589 00 37 00 (number 7).
Two-row angular-contact ball bearing (8)	remove, install. The angular-contact ball bearing must contact edge of wheel carrier. Extractor/pulling-in equipment 124 589 05 43 00 (number 8).
Bearing inner race of angular-contact ball bearing (8)	remove from rear axle shaft flange (numbers 9-11). Puller base equipment 001 589 50 33 00 or 001 589 36 33 00, collet chuck 201 589 00 34 00, thrust piece 000 589 03 34 00, open end wrench WAF 55x65 mm 140 589 00 01 00, open end wrench WAF 41 mm 201 589 00 01 00.
All parts	check for re-use (number 12).
Radial and lateral runout of rear axle shaft flange (10)	check, nominal value 0.03 mm (number 12).

Special tools

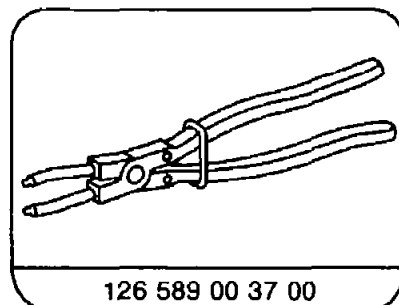
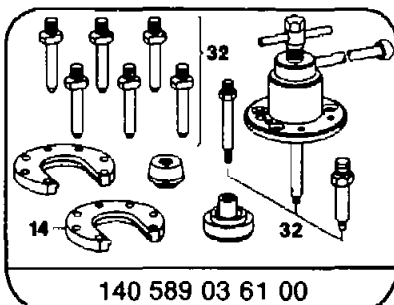
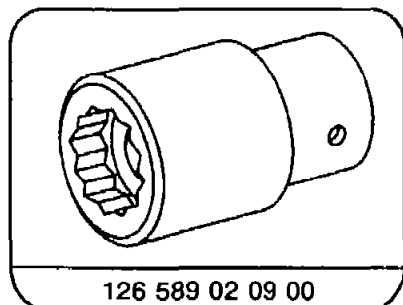

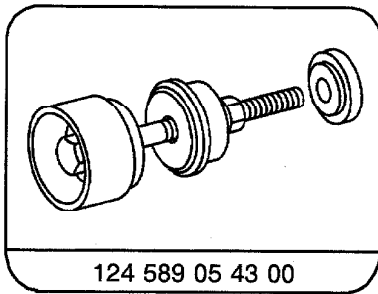

124 589 05 43 00

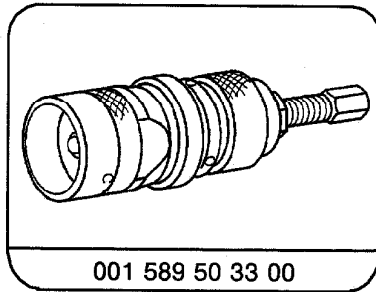

001 589 50 33 00

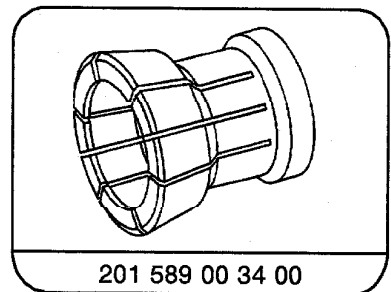

201 589 00 34 00

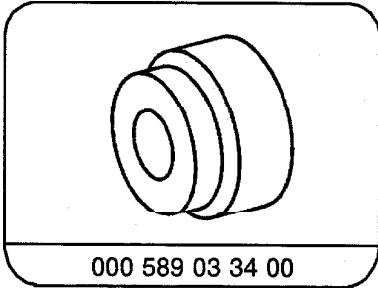

000 589 03 34 00

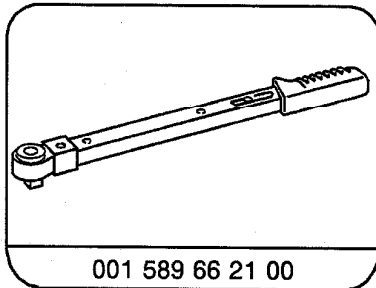

001 589 66 21 00

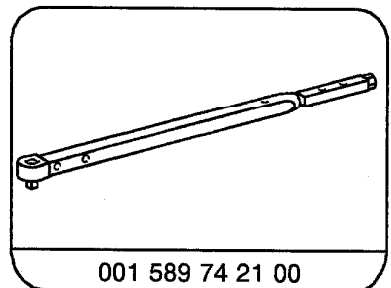

001 589 74 21 00

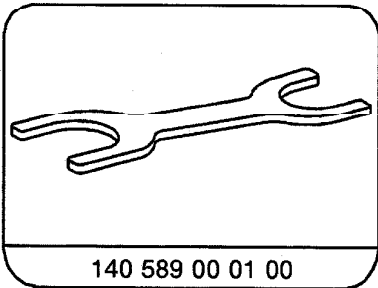

140 589 00 01 00

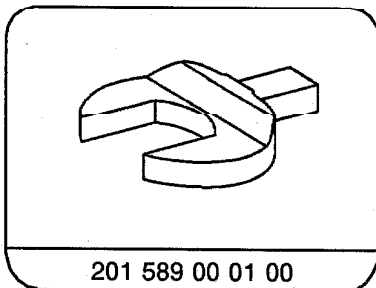

201 589 00 01 00

Note

Work can also be carried out on the mounting of the rear axle shaft flange when the rear axle is installed.

- 7 Wheel carrier
- 8 Two-row angular-contact ball bearing
- 9 Circlip
- 10 Rear axle shaft flange
- 11 Parallel pin
- 12 Twelve-point collar nut
- 37a Rear axle shaft
- 37b Outer joint race
- 37d Joint hub
- 37e Ball
- 37f Ball cage
- 37g Circlip
- 37k Hose clamp
- 37l Rubber cup seal

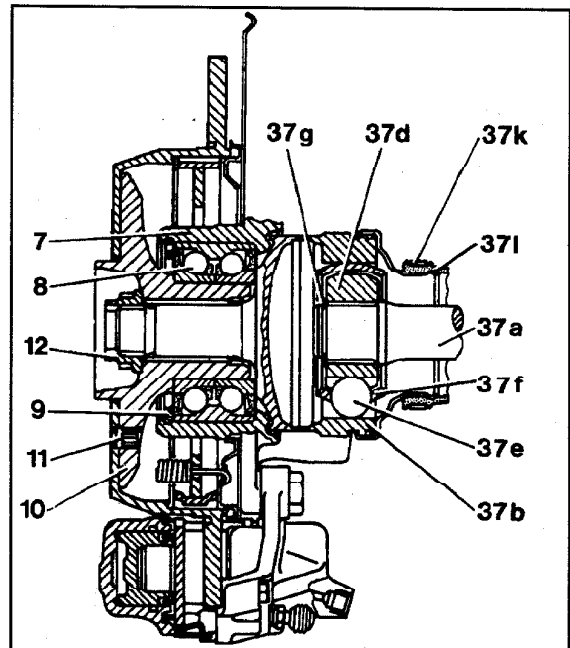

P35-5512-15

Removal, installation

- 1 Remove, install rear axle shaft (35–620).

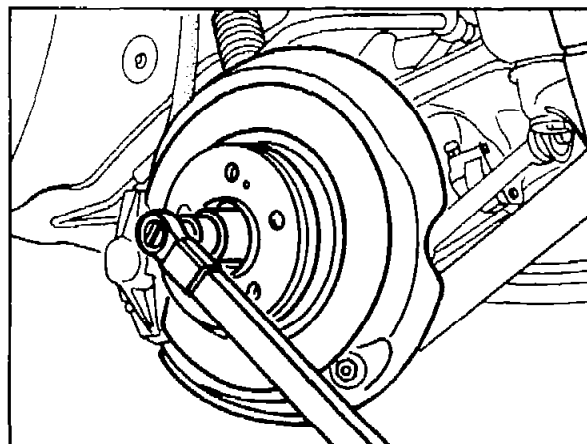

P35-5514-13

- 2 If it is tightly seated, use extractor/pulling-in equipment 140 589 03 61 00 to press rear axle shaft out of rear axle shaft flange.

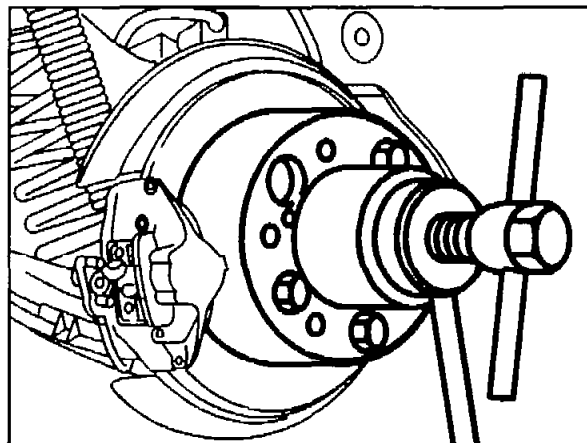

P35-5897-13

- 3 Remove, install brake calliper (111) and suspend on a hook (41–120).

Installation note

Replace self-locking hexagon bolt. Install brake hose and, on vehicles with ASR, install electric cable of wear indicator (111h) without twisting.

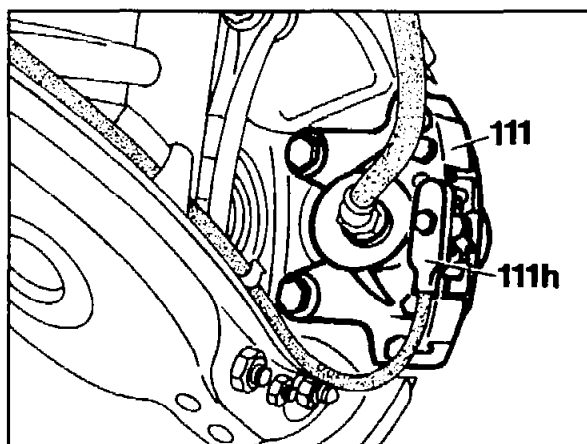

P35-5461-13

- 4 Remove, install brake disk (111c) (42–228).

Installation note

Replace self-locking hexagon socket bolt (111d).

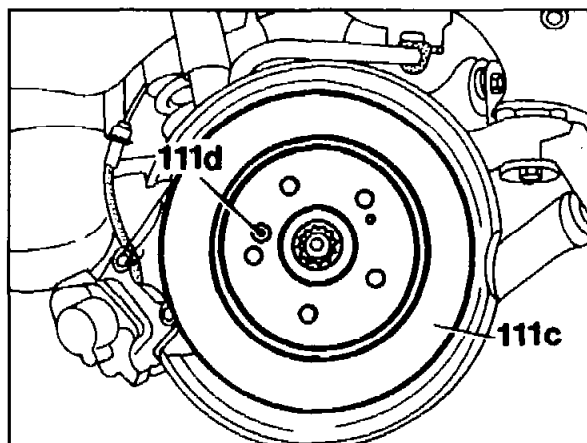

P35-5518-13

5 Remove, install brake shoes (112) of parking brake (42-530).

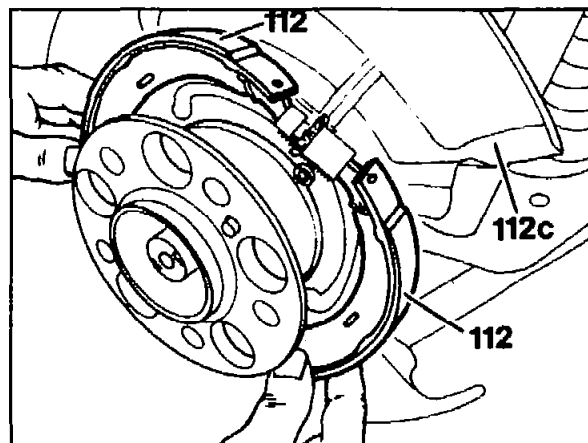

P35-5519-13

6 Using extractor/pulling-in equipment (010) 140 589 03 61 00 with set bolt (010b) and thrust piece (010a), pull rear axle shaft flange (10) out of angular-contact ball bearing (8) and remove.

- 7 Wheel carrier
- 8 Two-row angular-contact ball bearing
- 10 Rear axle shaft flange
- 010 Extractor/pulling-in equipment
- 010a Thrust piece
- 010b Set bolt
- 010c Threaded bolt
- 010d Support plate

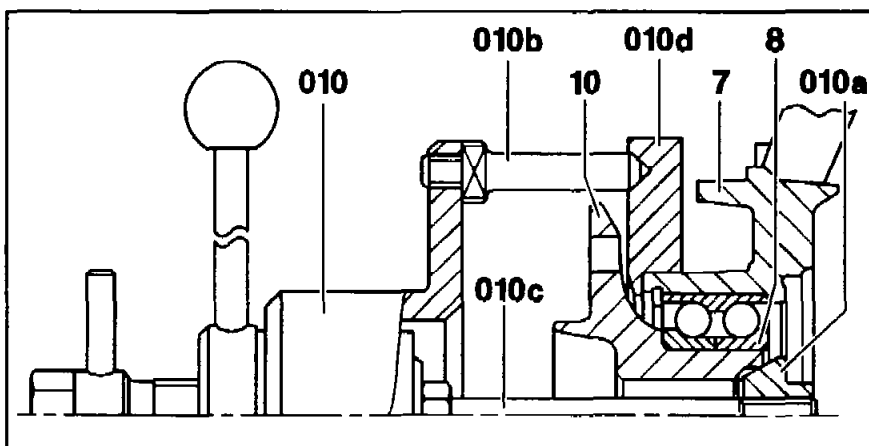

P35-5889-33

Installation note

Using extractor/pulling-in equipment (08a, 08b, 08c and 08e) 124 589 05 43 00 draw rear axle shaft flange (10) into two-row angular-contact ball bearing (8).



During the pulling-in process, the thrust washer 124 589 05 43 00, part 03 (08c) must fit tightly against the bearing inner race (arrow). In the case of the two-row angular-contact ball bearing, use the thrust washer side of 45 mm dia. (smaller dia.) and in the case of the two-row angular-contact roller bearing, use the thrust washer side of 49 mm dia. (larger dia., T-model only).

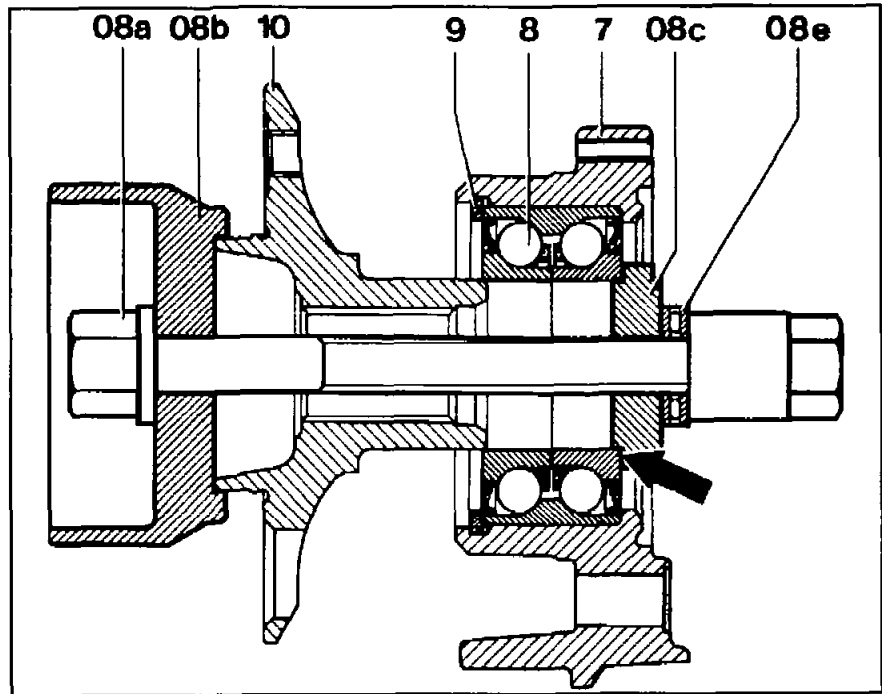

P35-5530-35

- 7 Wheel carrier
- 8 Two-row angular-contact ball bearing
- 9 Circlip
- 10 Rear axle shaft flange
- 08a Hexagon bolt with collar nut
- 08b Extractor/pulling-in sleeve
- 08c Thrust washer (small, 45 mm dia.)
- 08e Thrust bearing

7 Remove circlip (9) from wheel carrier using circlip pliers 126 589 00 37 00.

Installation note

Ensure correct seating of the circlip in the wheel carrier.

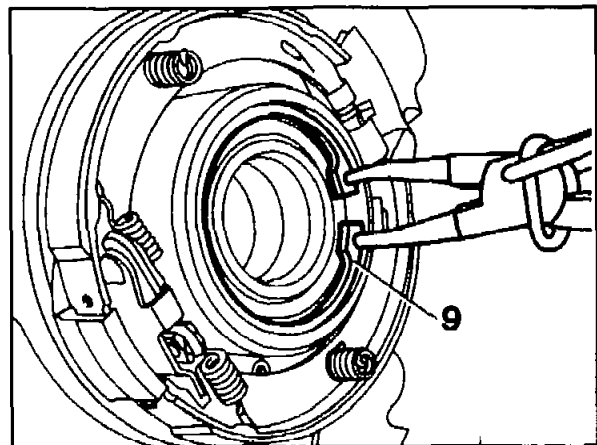

P35-5532-13

8 Using extractor/pulling-in equipment (08a, 08b, 08c and 08e) 124 589 05 43 00, pull two-row angular-contact ball bearing (8) out of wheel carrier (7) and remove.

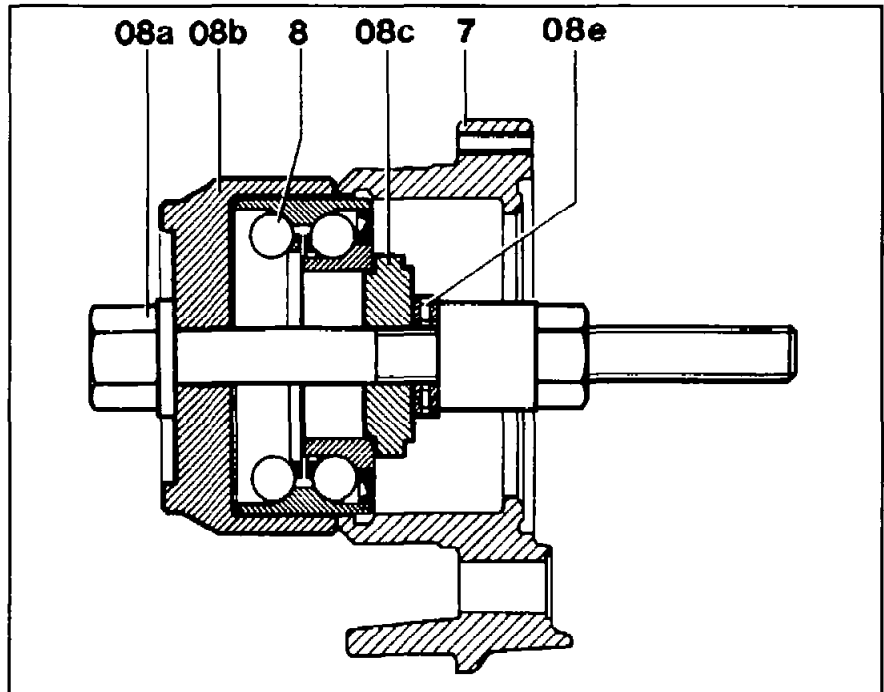

- 7 Wheel carrier
- 8 Two-row angular-contact ball bearing
- 08a Hexagon bolt with collar nut
- 08b Extractor/pulling-in sleeve
- 08c Thrust washer (small, 45 mm dia.)
- 08e Thrust bearing

P35-5535-35

Installation note

Using extractor/pulling-in equipment

124 589 05 43 00 (08a, 08b, 08d and 08e), pull two-row angular-contact ball bearing (8) into wheel carrier (7) until this contacts the edge (arrow).

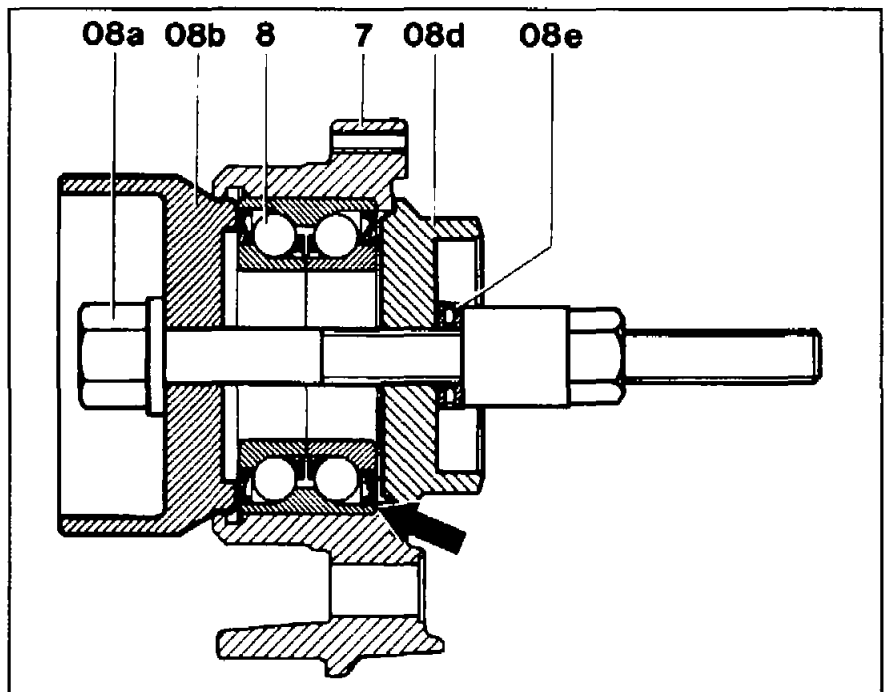

- 7 Wheel carrier
- 8 Two-row angular-contact ball bearing
- 08a Hexagon bolt with collar nut
- 08b Extractor/pulling-in sleeve
- 08d Thrust washer (large)
- 08e Thrust bearing

P35-5534-35

9 Screw collet chuck (08f) 201 589 00 34 00 onto basic puller equipment (08g) 001 589 50 33 00 or 001 589 36 33 00 and tighten with 55x65 open end wrench 140 589 00 01 00.

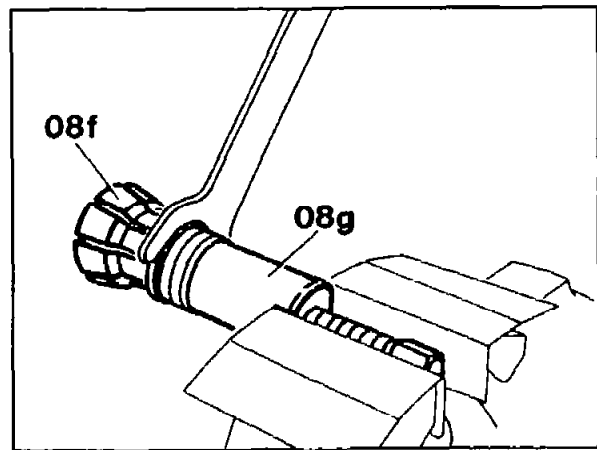

P35-5531-13

10 Using aluminium jaws clamp rear axle shaft flange in vise. Place thrust piece (010b) 000 589 03 34 00 with large diameter on rear axle shaft flange (10).

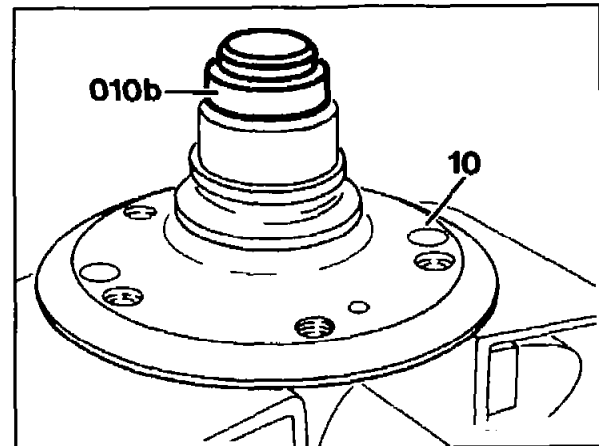

P35-5555-13

11 Clamp puller on bearing inner race, using puller 001 589 50 33 00 or 001 589 36 33 00 and collet chuck 201 589 00 34 00 pull bearing inner race off rear axle shaft flange. 41 mm open end wrench 201 589 00 01 00.

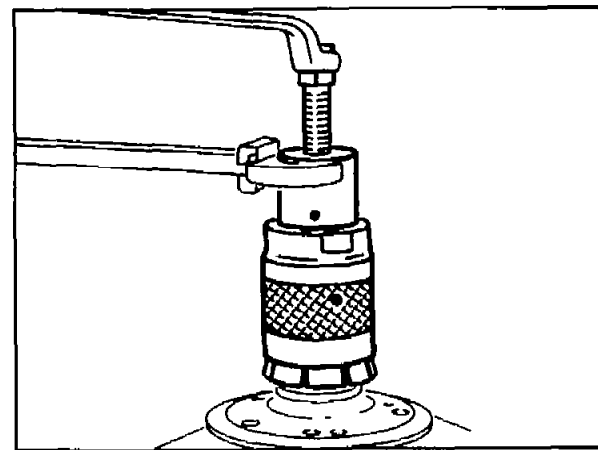

P35-5556-13

Testing

12 Check all parts to make sure they can be re-used. Check radial and lateral runout of rear axle shaft flange (nominal value 0.03 mm). Always replace two-row angular-contact ball bearing after it has been used once.

13 Install in reverse sequence.