

**35-530 Replacement of radial sealing ring on bevel drive pinion
(rear axle center assembly installed)**

Operation no. of operation texts and work units
or standard texts and flat rates:
35-0130

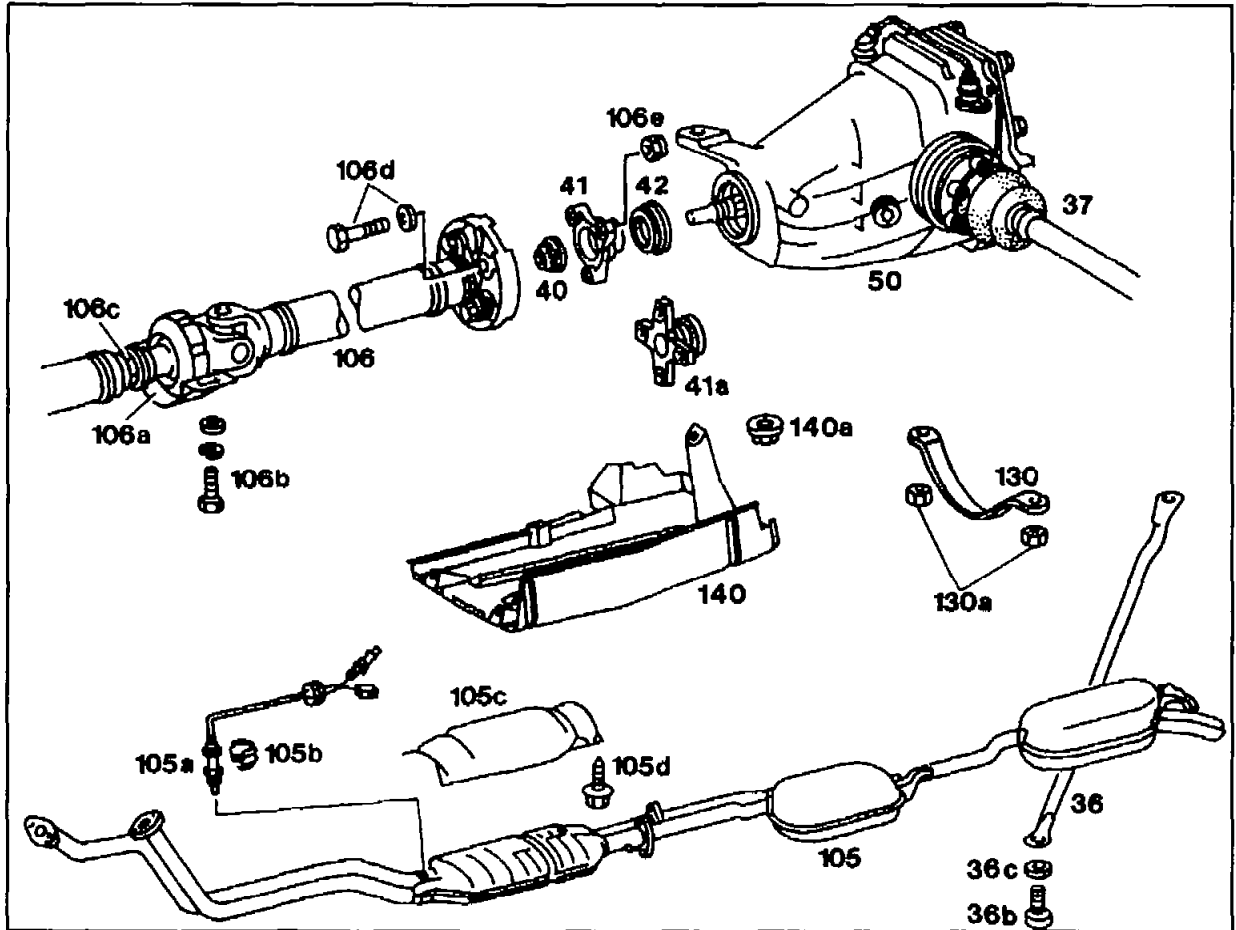

P35-5903-57

Model 124.06 (convertible)

Cross brace (36)

Remove, install on the left. Replace self-locking polygon head bolts (36b), tightening torque, 120 Nm (number 1).
Torque wrench 001 589 66 21 00.



The body must be jacked up without any distortion when working on diagonal struts. A twin-pillar hoist can be used for this.

All models

Exhaust system (105)	Remove from plug connection, install (49–100, number 2).
Exhaust shield (105c)	Remove, install (number 3).
Clamp nut (106c)	Loosen, tighten at propeller shaft. Tightening torque 30–40 Nm. Torque wrench 001 589 66 21 00, open end wrench 46 mm 126 589 00 01 00 or open end wrench 41 mm 201 589 00 01 00 (number 4).
Propeller shaft intermediate bearing (106a)	Loosen, tighten at frame floor. Tightening torque of hexagon bolts 25 Nm. Torque wrench 001 589 66 21 00 (number 5).
Cover (140) for fuel pump assembly	Remove, install (number 6).
Bracket (130) for seat belt attachment	Remove, install. Tightening torque 210 Nm. Torque wrench 000 589 10 99 01 (number 7).
Propeller shaft (106)	Disconnect, connect at flange of rear axle center assembly. Push rear propeller shaft (106) forwards out of centering device, remove and secure it to prevent it from falling down. Replace self-locking hexagon nuts. Tightening torque M10 = 40 Nm, M12 = 60 Nm. Torque wrench 001 589 66 21 00 (numbers 8 and 9).
Friction moment	Measure and note. Torque measuring equipment 001 589 49 21 00. Socket wrench insert 30 mm 126 589 02 09 00 Socket wrench insert 27 mm 201 589 00 09 00 Connecting piece 3/4" 100 589 02 69 00 (number 10).
Twelve-point collar nut (40)	Loosen, replace and tighten in stages, until the measured moment is attained (number 11). Secure twelve-point collar nut. Retaining wrench 129 589 01 07 00 socket wrench insert 30 mm 126 589 02 09 00 and 27 mm 210 589 00 09 00. Torque wrench 001 589 74 21 00.
Joint flange (41/41a)	Disconnect, connect. If required, pull joint flange using puller 129 589 01 33 00 (number 12).

Radial sealing ring (42)	Press out, replace, press in (number 13). Impact drift 124 584 02 15 00 for 185/210 mm dia. crown wheel or impact drift 201 589 00 15 00 for 168 mm dia. crown wheel.
Oil level	Check, correct if required (number 14).

Special tools

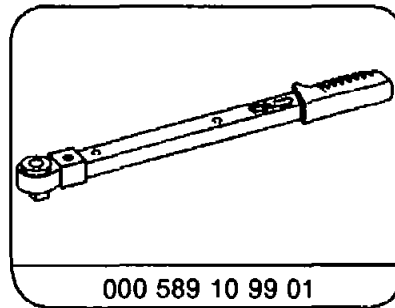
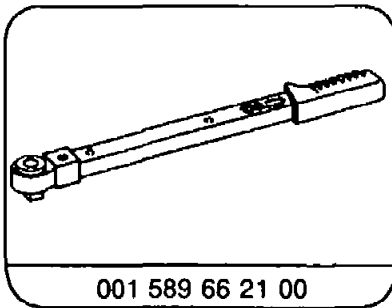
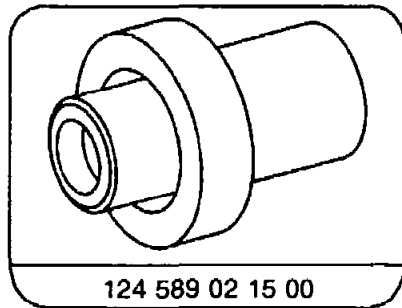
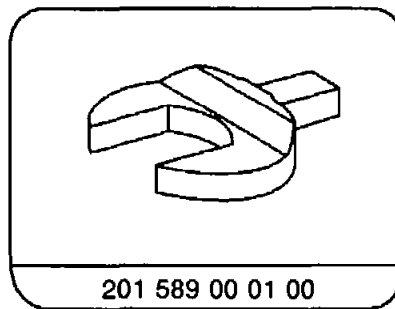
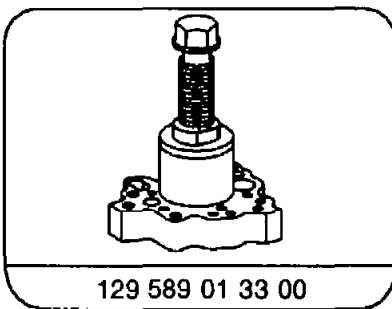
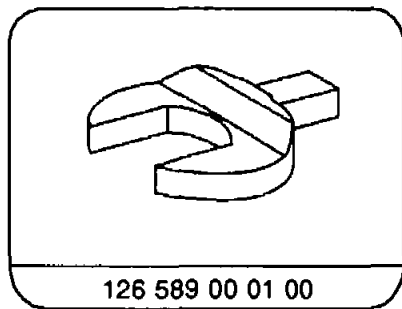
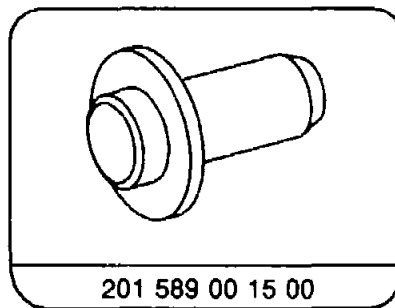
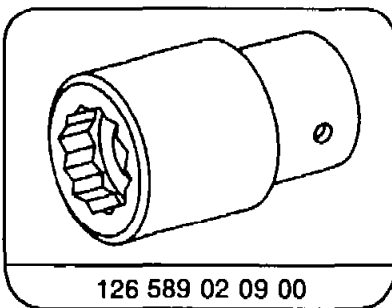
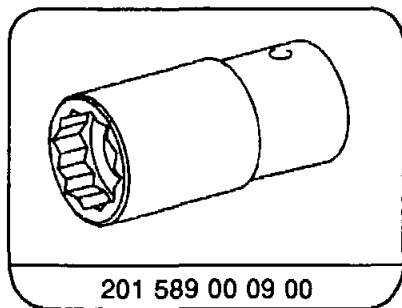
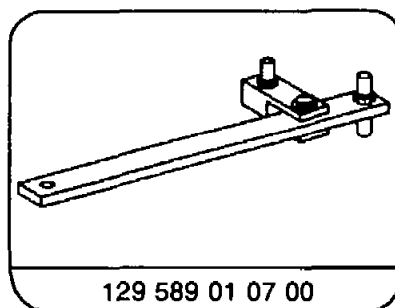
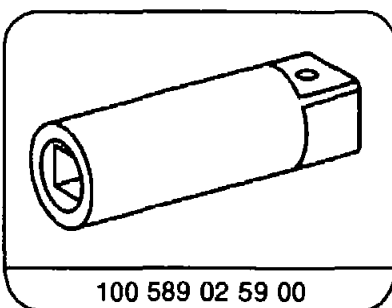
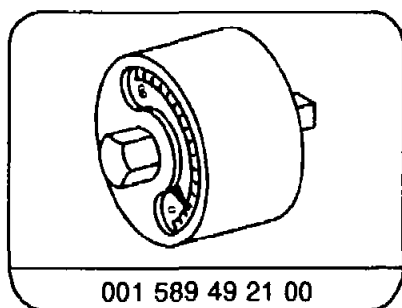

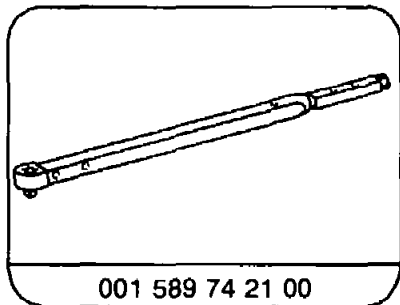

Types of oil and capacity

Standard differential	SAE 90 hypoid gear oil Refer to Specifications for Service Products, sheet no. 235
Differential with ASD (information plate on rear axle housing)	Special hypoid gear oil Refer to Specifications for Service Products, sheet no. 235.3
Capacity	with 168 mm dia. crown wheel, 0.7 liter, with 185 mm dia. crown wheel, 1.1 liter. with 210 mm dia. crown wheel, 1.3 liter.

Removal, Installation

Model 124.06 (convertible)

- 1 Remove left cross brace (36) on frame floor.

Installation note

Replace self-locking polygon head bolts.
Tightening torque 120 Nm.
Torque wrench 001 589 66 21 00.



The body must be jacked up without any distortion when working on diagonal struts. A twin-pillar hoist can be used for this.

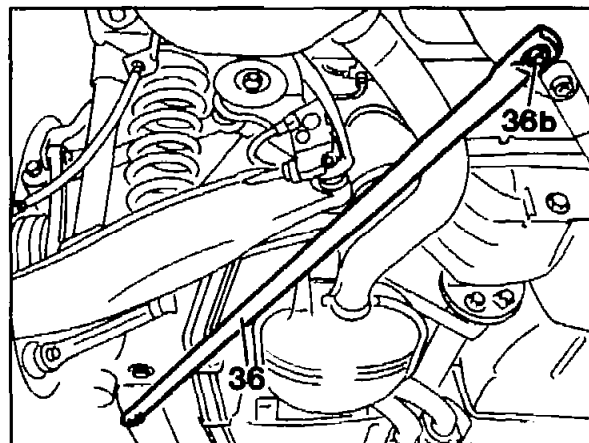

P35-5588-13

All models

2 Remove exhaust system from plug connection (49–100).

3 Remove exhaust shield (105c).

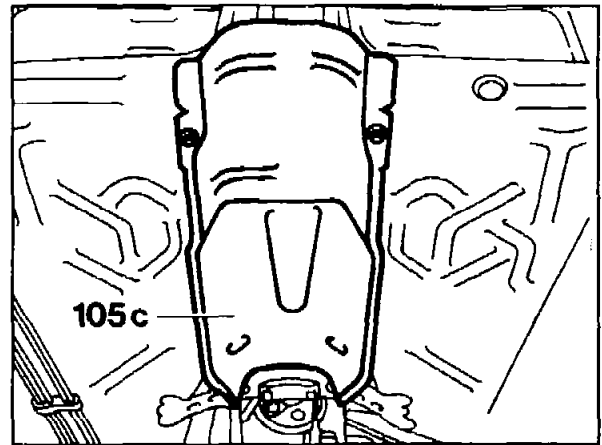

P35-5456-13

4 Loosen clamp nut of propeller shaft. Open end wrench 41 mm 201 589 00 01 00 or open end wrench 46 mm 126 589 00 01 00.

Installation note

Tightening torque of clamp nut 30 – 40 Nm.
Torque wrench 001 589 66 21 00.

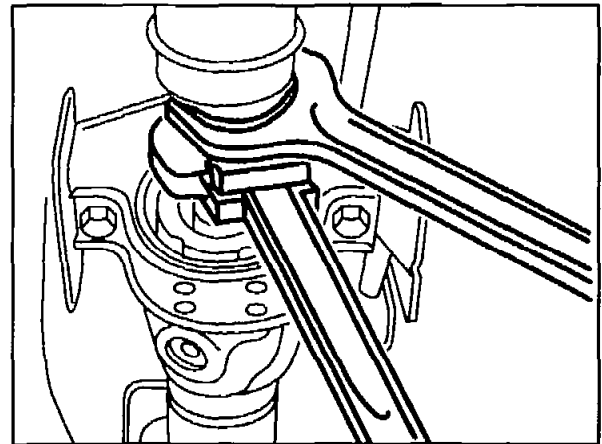

P41-2005-13

5 Loosen propeller shaft intermediate bearing (106c) on frame floor.

Installation note

Tightening torque 25 Nm.
Torque wrench 001 589 66 21 00.

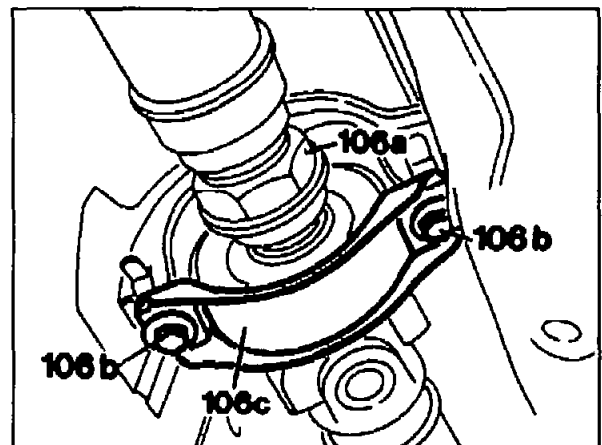

P35-5439-13

6 Remove cover for fuel pump assembly (140) (arrows).

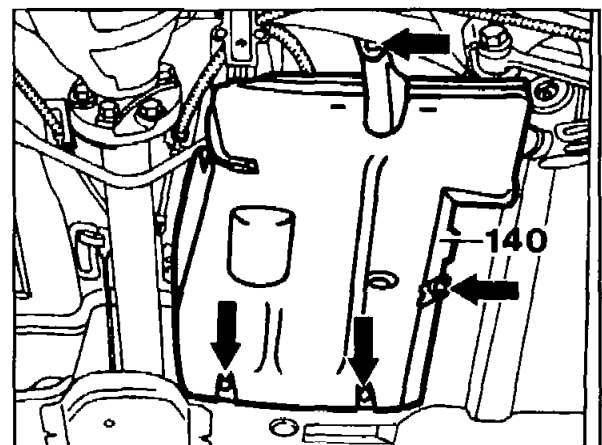

P35-5457-13

7 Remove bracket (130) for seat belt attachment.

Installation note

Tightening torque 280 Nm.

Torque wrench 000 589 10 99 01.

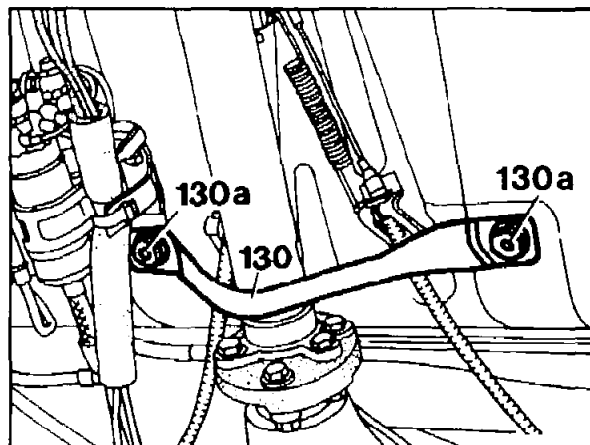

P35-5458-13

8 Disconnect propeller shaft at flange of rear axle center assembly (arrows).

Installation note

Replace self-locking hexagon nuts. Tightening torque of hexagon bolts M10 = 40 Nm, M12 = 60 Nm.

Torque wrench 001 589 66 21 00.

9 Push rear propeller shaft forwards out of centering device and prevent it from falling down.

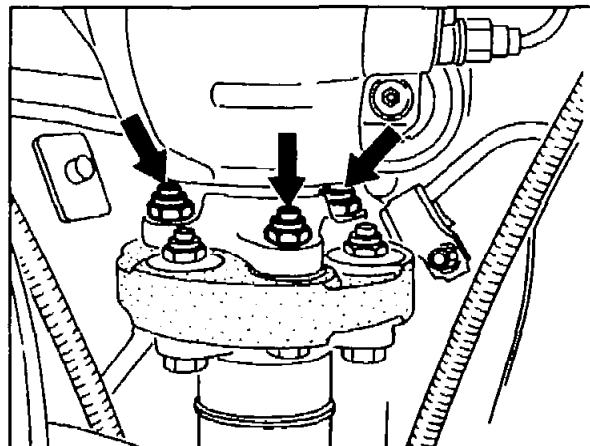

P35-5440-13

10 Measure friction torque of complete rear axle drive and note. Torque measuring equipment 001 589 49 21 00. Socket wrench insert 27 mm 201 589 00 09 00 for crown wheel dia. 168 mm and 30 mm 126 589 02 09 00 for 185/210 mm dia. crown wheel. 3/4" connector 100 589 02 59 00.

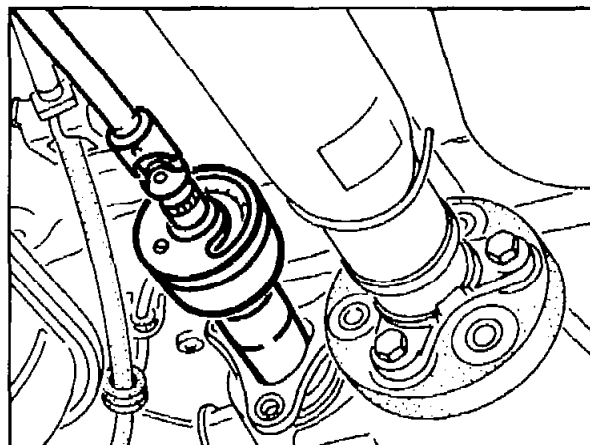

P35-5549-13



When measuring the friction torque, ensure that the rear axle shafts are approximately horizontal and that the brake pads do not rub on the brake disk and that the brake shoes of the parking brake do not rub on the drum.

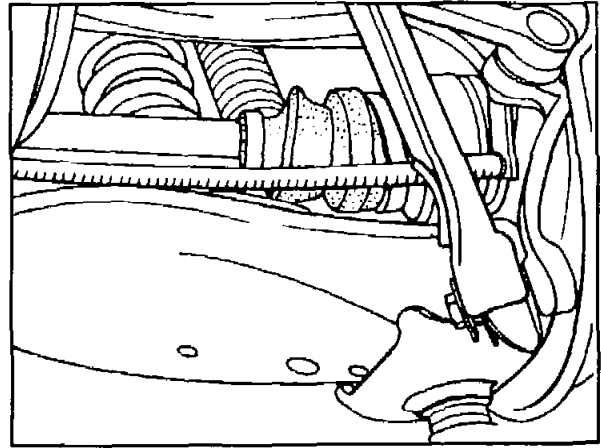

P35-5480-13

- 11 Place retaining wrench (040) 129 589 01 07 00 on the propeller shaft flange and loosen the twelve-point collar nut using socket wrench insert 30 mm (040a) 126 589 02 09 00 or with 27 mm 201 589 00 09 00 and remove.

Note

On model 201 use a suitable ring wrench (arrow) to support the retaining wrench. Do not unlock the twelve-point collar nut, but only loosen.

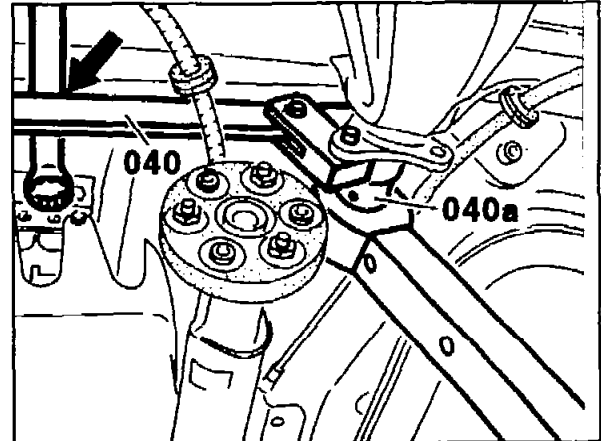

P35-5550-13

Installation note

Replace twelve-point collar nut and tighten in stages until the noted friction moment is achieved. The tightening torque must be at least 90 Nm in the case of the center assembly with the crown wheel dia. 168 mm and 180 Nm in the case of center assemblies with the 185/210 mm dia. crown wheel. If this is not attained, the resilient distance sleeve must be replaced.

Using a caulking tool in one of the two grooves of the bevel drive pinion, caulk the twelve-point collar nut so that there is no gap between the groove and the safety tabs.



Do not apply any heavy axial blows.

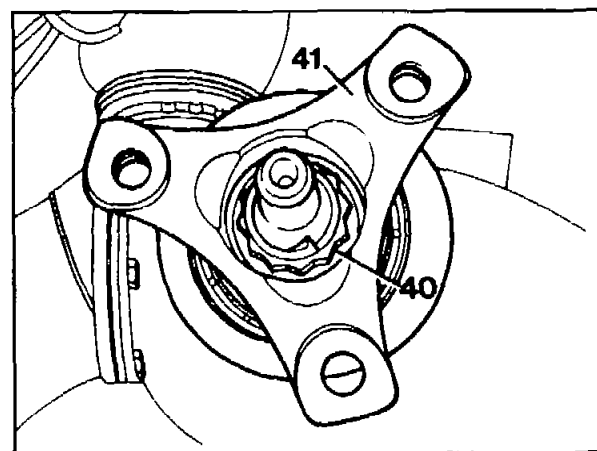

P35-2051-13

12 Pull off joint flange (41), if required using puller 129 589 01 33 00 and remove.

Installation note

Check contact surface for the radial sealing ring on the joint flange. If the contact surface is worn, replace joint flange.

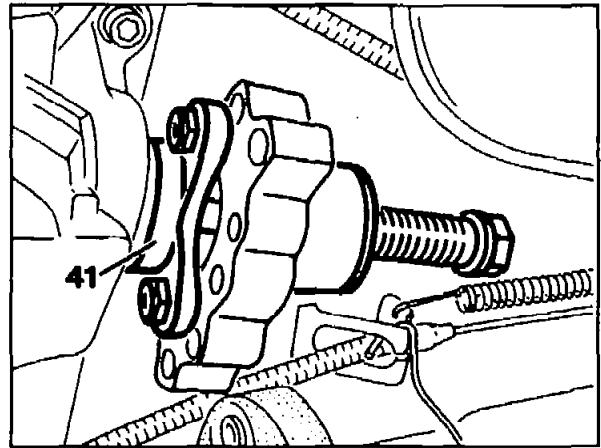

P35-5551-13

13 Using a suitable screwdriver, press radial sealing ring out of rear axle housing.

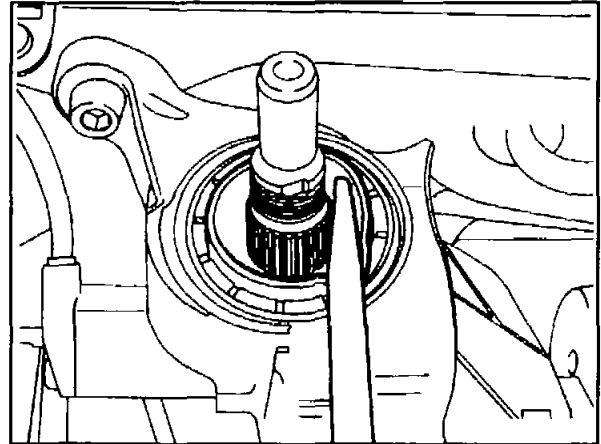

Location on model 201

P35-2123-13

Installation note

Using the impact drift (042), drive radial sealing ring (42) in as far as the stop in the rear axle housing. Impact drift 124 589 02 15 00 with 185 and 210 mm dia. crown wheel or 201 589 00 15 00 with 168 mm dia. crown wheel.

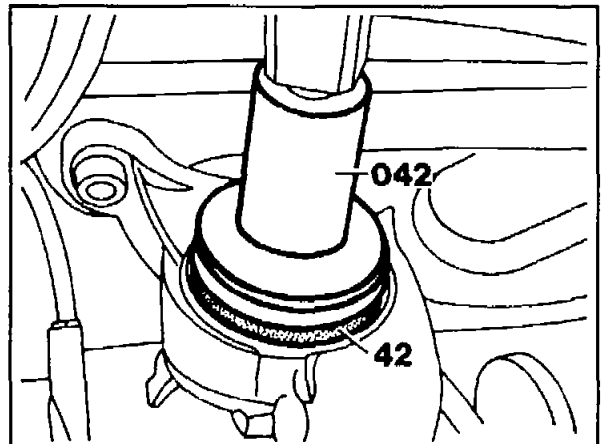

Location on model 201

P35-5557-13

14 Check oil level and correct if required (refer to Specifications for Service Products 235 and 235.3).

15 Install in reverse sequence.