

35-540 Replacement of radial sealing ring on connecting flange of rear axle shaft

Preceding work:
Remove, install rear axle center assembly (35-520).

Operation no. of operation texts and work units
or standard texts and flat rates:
35-0138, 35-0139, 35-0143

Note

For installation survey of individual rear axle center assemblies, refer to 35-500 rear axle center assembly with 168 mm, 185 mm and 210 mm dia. crown wheel.

Note

A leaking radial sealing ring can only be replaced when the rear axle center assembly is removed. Thoroughly clean rear axle housing in the area of the bearing cap, so that no dirt can enter the rear axle housing.

A. Rear axle center assembly with 168 mm dia. crown wheel

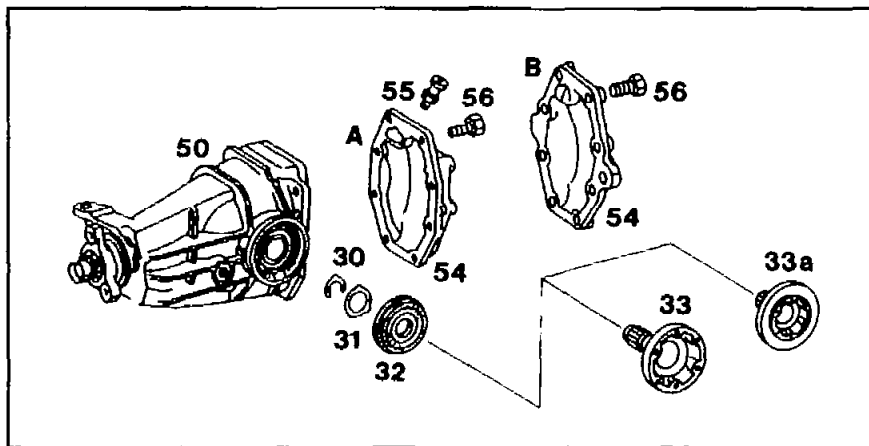

P35-5558-33

- A. Rear axle closing plate - model 201
- B. Rear axle closing plate - model 124

Rear axle oil	Drain, fill. Filling height up to lower edge of filler opening (capacity, 0.7 liters) Tightening torque 50 Nm (number 1)
Rear axle center assembly (50)	Clamp in clamping fixture 201 589 03 31 00 (number 2).
Rear axle closing plate (54)	Remove, install. Clean sealing surfaces and coat with sealing agent. Tightening torque of hexagon bolts (56) in strength class 8.8 = 45 Nm, 10.9 = 50 Nm (number 3). Torque wrench 001 589 66 21 00.
Rear axle breather (55)	Replace, tightening torque 25 Nm.
Circlips (30)	Remove, replace and install. Hook 116 589 01 62 00 (number 4).
Connecting flange (33 or 33a)	Remove, install. Check axial play and adjust (number 5).
Radial sealing ring (32)	Remove, replace and install. Assembly tool 201 589 03 15 00 (number 6).
Shim (31)	Remove, replace and install (number 7).

Special tools

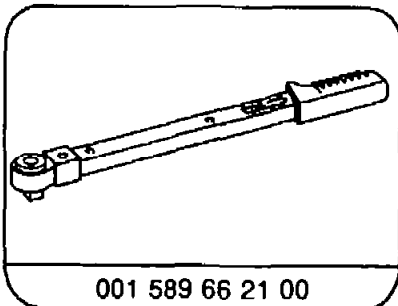
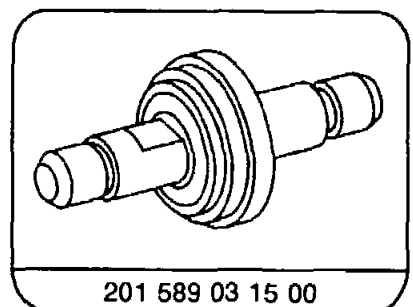
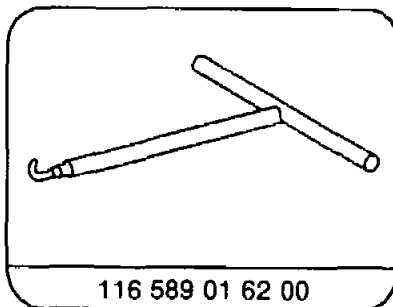
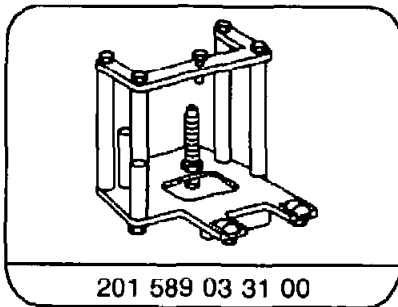

Types of oil and capacity

Standard differential	SAE 90 hypoid gear oil Refer to Specifications for Service Products, sheet no. 235
Capacity	0.7 liter

Circlips for adjusting axial play of connecting flanges

Thickness	1.20–1.80 mm
Graduation	0.05–0.05 mm

Removal, installation

- 1 Drain rear axle oil.

Installation note

The oil should come up to the bottom edge of the filler opening. For types of oil, refer to table "Types of oil and capacity". Tightening torque for plug 50 Nm.

- 2 Clamp rear axle center assembly in clamping fixture (054) 201 589 03 31 00 and tighten with hexagon socket bolt (054d) and hexagon bolt (054a). At the same time ensure correct seating of the center assembly in the clamping fixture (arrows).

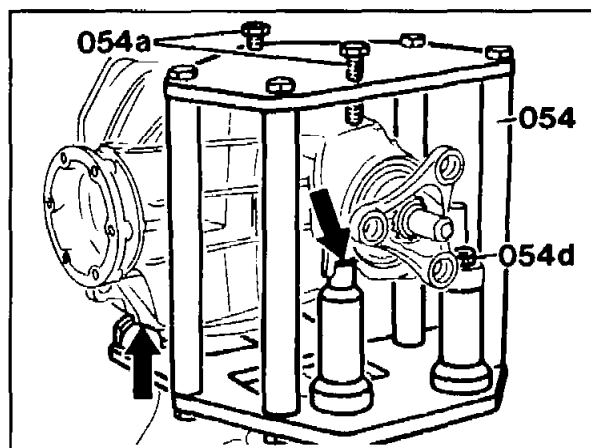

P35-5196-13

3 Remove rear axle closing plate (54).

Installation note

Replace rear axle breather. Clean sealing surfaces on rear axle closing plate and rear axle center assembly, and coat with sealing compound. Tightening torque of hexagon bolt in strength class 8.8 = 45 Nm, 10.9 = 50 Nm. Torque wrench 001 589 66 21 00.

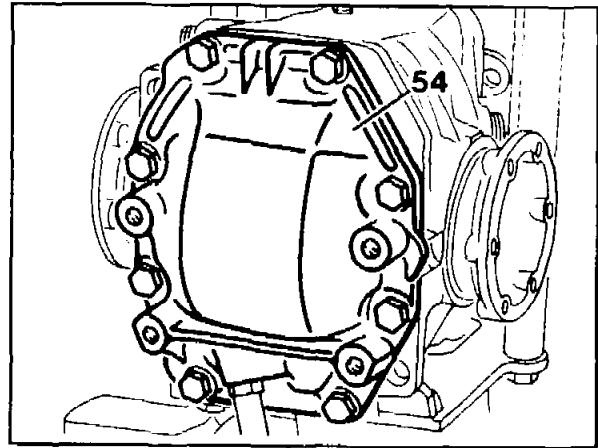

P35-5197-13

Rear axle closing plate - model 201

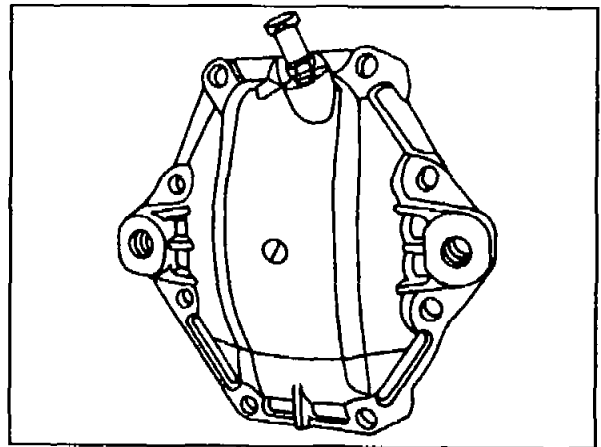

Rear axle closing plate - model 124

P35-5559-13

4 Detach circlip (30) from connecting flange using hook 116 589 01 62 00.

Installation note

Replace circlip. Check axial play. There should be no detectable axial play. However the circlip should still be able to turn in the groove. If required, install thinner or thicker circlip.

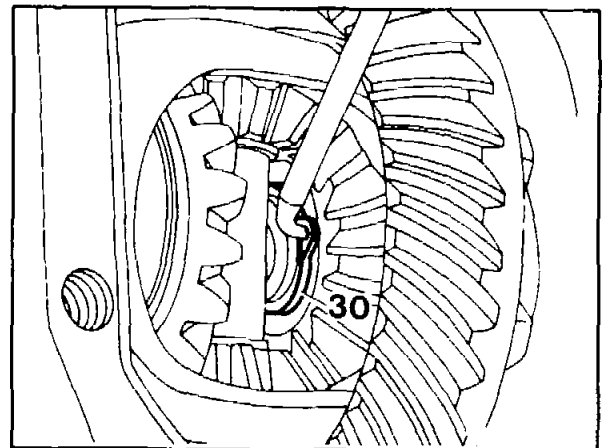

P35-5317-13

5 Pull connecting flange (33a) out of differential side gears.

Installation note

Check contact surface on the connecting flange for the radial sealing ring, replace connecting flange if required.

33a Connecting flange with annular mass

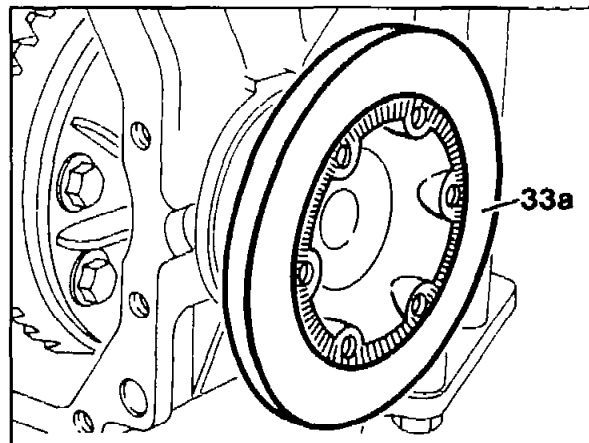

P35-5198-13

6 Using a suitable screwdriver, press radial sealing ring (32) out of rear axle housing.

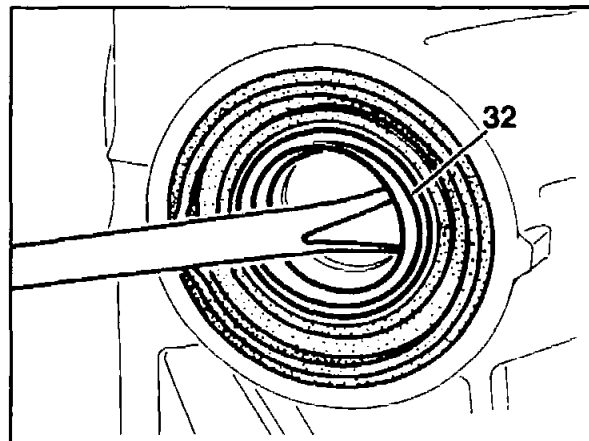

P35-5195-13

Installation note

Using assembly alignment tool (049b) 201 589 03 15 00, press partially rubberized radial sealing ring (32) into rear axle housing. Lightly coat sealing lip of radial sealing ring with hypoid gear oil.

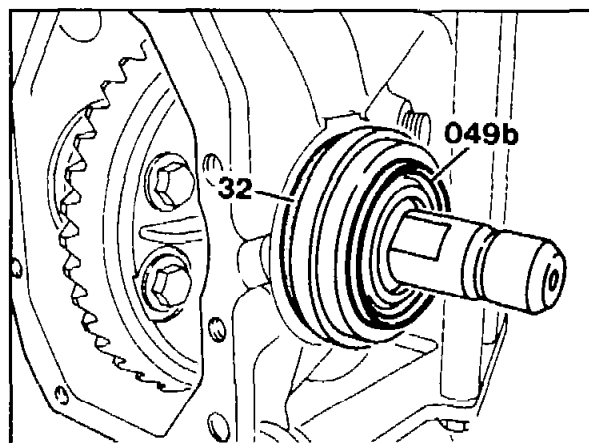

P35-5211-13

7 Shim (31) must make good contact with the end face of the differential housing, check (arrow).

8 Install in reverse sequence.

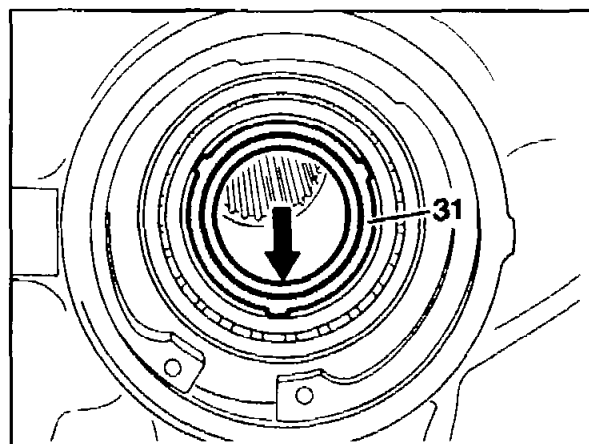

P35-5224-13

B. Rear axle center assembly with 185 mm dia. crown wheel

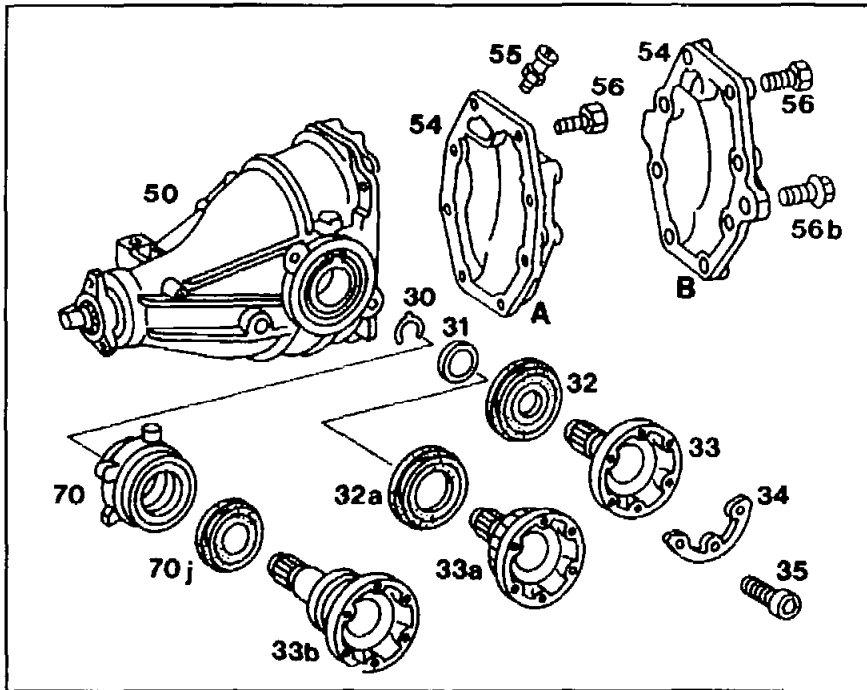

P35-5560-35

- A. Rear axle closing plate - model 201
- B. Rear axle closing plate - model 124

Rear axle oil	Drain, fill. Filling height up to lower edge of filler opening. Tightening torque 50 Nm (number 1).
Rear axle center assembly (50)	Clamp in clamping fixture 129 589 00 31 00 (number 2).
Rear axle closing plate (54)	Remove, install. Clean sealing surfaces and coat with sealing agent. Tightening torque of hexagon bolts (56) in strength class 8.8 = 45 Nm, 10.9 = 50 Nm, and with collar bolts (56b) = 55 Nm. Torque wrench 001 589 66 21 00 (number 3).
Rear axle breather (55)	Replace. Tightening torque 25 Nm.
Circlips (30)	Remove, replace and install. Hook 116 589 01 62 00 (number 4).
Connecting flange (33, 33a, 33b) with spacers (31)	Remove, install. Adjust axial play of connecting flanges (33, 33a), apart from rear axle center assembly with ASD (number 4).

On vehicles with ASD

Radial sealing ring (70)

Pull out, replace and press in (number 5).
Removal fixture 129 589 02 33 00 section 04.
Pressing-in tool 124 589 01 15 00.

On vehicles with ASR or standard differential

Radial sealing ring (32, 32a)

Remove, replace and install (number 6).
Standard differential:
assembly alignment tool 126 589 00 15 00.
ASR version:
assembly alignment tool 126 589 04 15 00.

Special tools

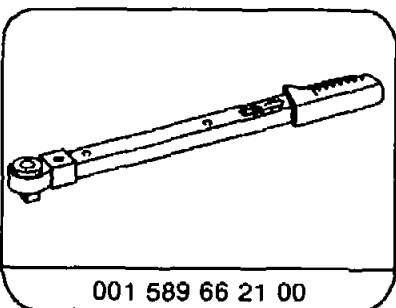
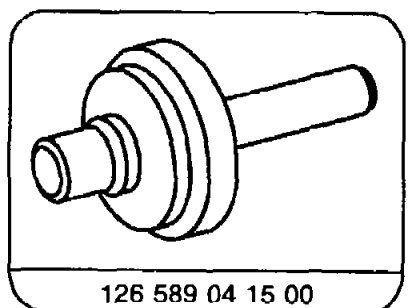
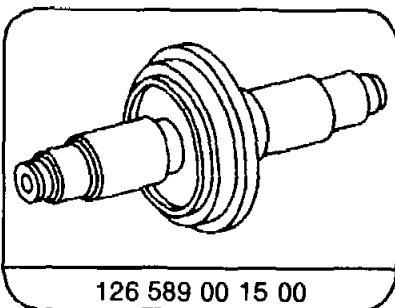
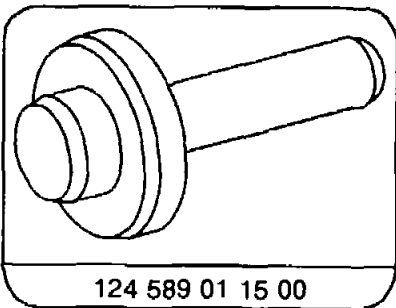
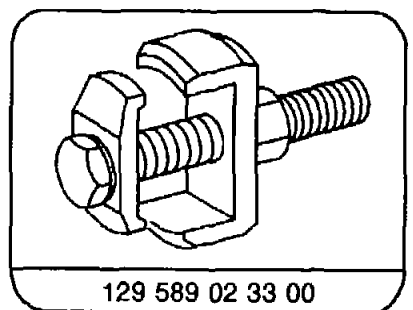
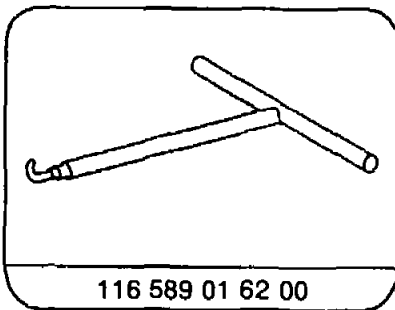
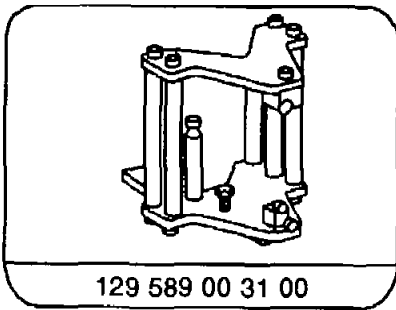

Spacer between Inner constant-velocity joint and differential housing

Thickness	0.7–1.5 mm
Graduation	0.1 to 0.1 mm

Types of oil and capacity

Standard differential Differential with ASR	SAE 90 hypoid gear oil, refer to Specifications for Service Products, sheet no. 235
Differential with ASD	Special hypoid gear oil, refer to Specifications for Service Products, sheet no. 235.3
Capacity	1.1 liters

Removal, Installation

- 1 Drain rear axle oil.

Installation note

The oil should come up to the bottom edge of the filler opening. For types of oil, refer to table "Types of oil and capacity". Tightening torque for plug 50 Nm.

- 2 Clamp rear axle center assembly in clamping fixture (054) 129 589 00 31 00 with locator parts (054a) 129 589 00 31 00 section 15 and (054b) 129 589 00 31 00 section 09.

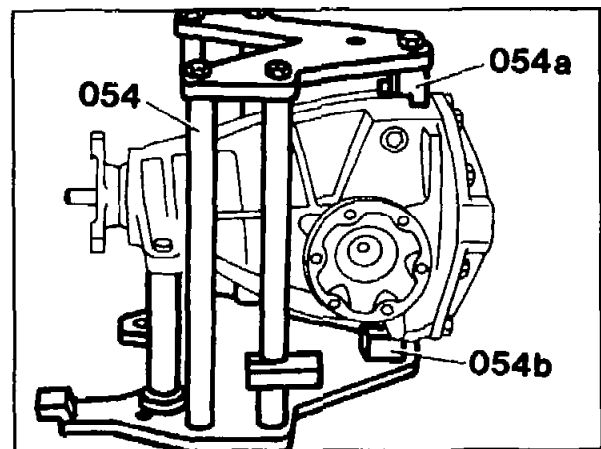

P35-5561-13

3 Remove rear axle closing plate (54) from rear axle housing.

Installation note

Replace breather and tighten to 25 Nm. Clean sealing surfaces on rear axle closing plate and rear axle center assembly and coat with sealing compound. Tightening torque of hexagon bolts in strength class 8.8 = 45 Nm, 10.9 = 50 Nm, and in the case of collar bolts, 55 Nm. Torque wrench 001 589 66 21 00.

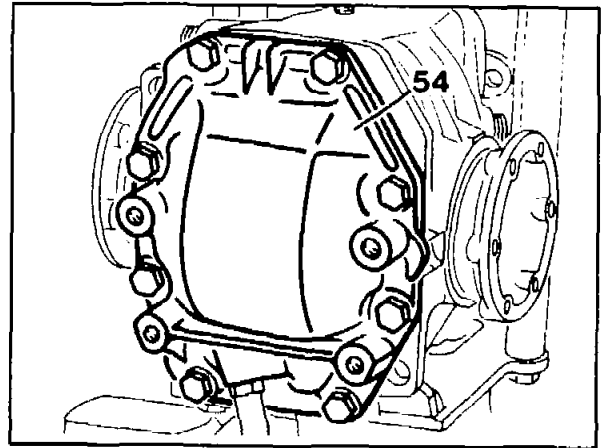

P35-5197-13

54 Rear axle closing plate - model 201

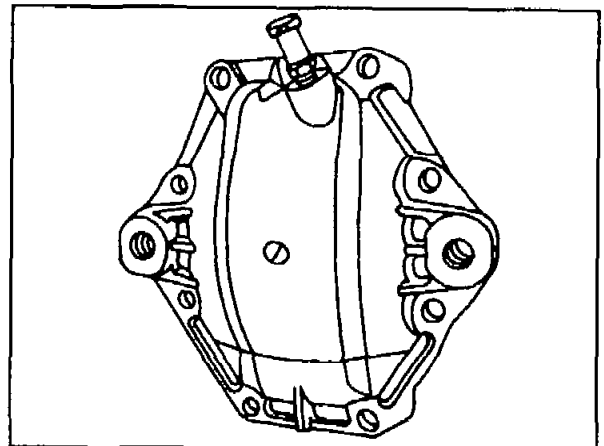

Rear axle closing plate - model 124

P35-5559-13

4 Detach circlip (30) from connecting flange using hook 116 589 01 62 00. Remove connecting flange with shim.

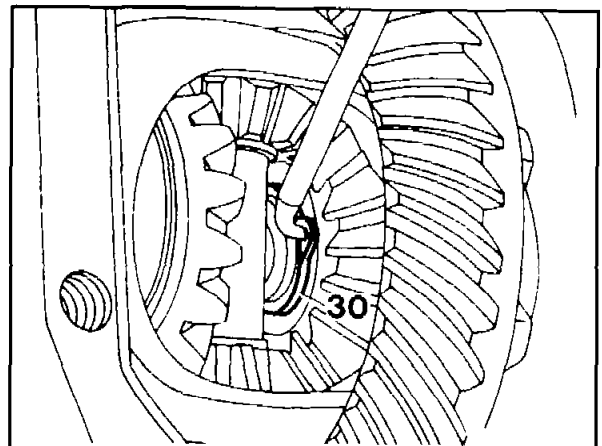

P35-5317-13

Installation note

Replace circlip. Check axial play (except on vehicles with ASD). There should be no detectable axial play; however the circlip should still be able to turn in the groove. If required, use a thicker or thinner spacer ring (31).

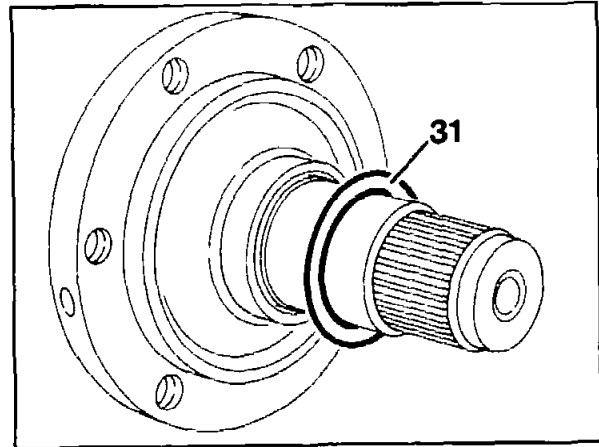

P35-5271-13

5 On vehicles with ASD

Pull radial sealing ring (70j) out of ring cylinder using removal tool (071) 129 589 02 33 00 section 04.

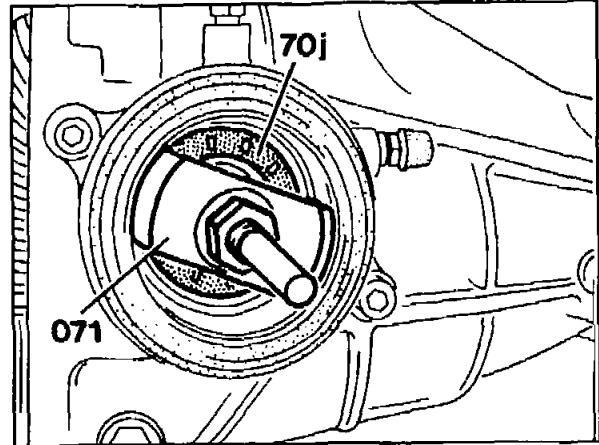

P35-5553-13

Installation note

Press in radial sealing ring (70j) using pressing-in tool 124 589 01 15 00. Lightly coat sealing lip with hypoid gear oil.

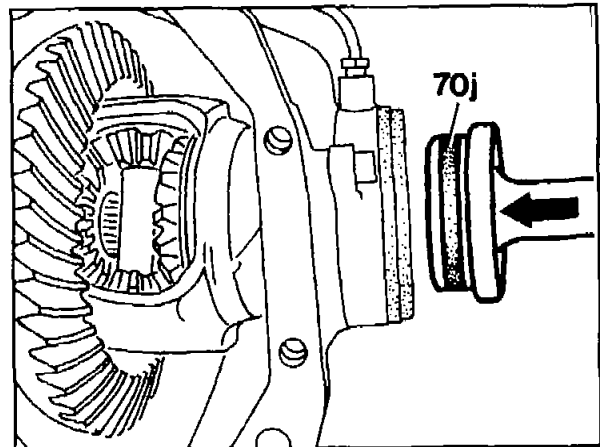

P35-5564-13

6 On vehicles with ASR or standard differential

Using suitable screwdriver, press radial sealing rings (32) out of rear axle housing.

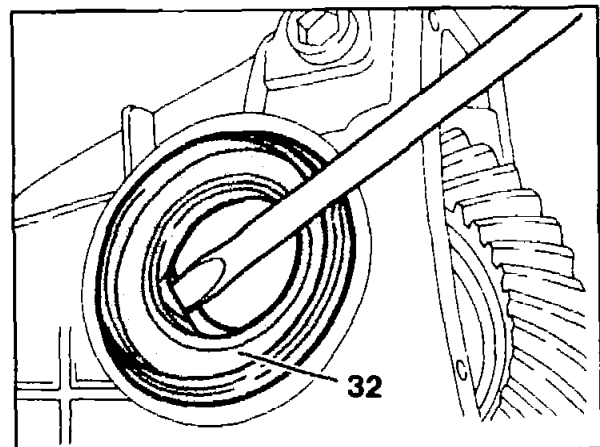

P35-5289-13

Installation note

Press partially rubberized radial sealing rings (32) into standard rear axle housing with drift punch (049b) 126 589 00 15 00. Coat sealing lip on radial sealing ring lightly with hypoid gear oil.

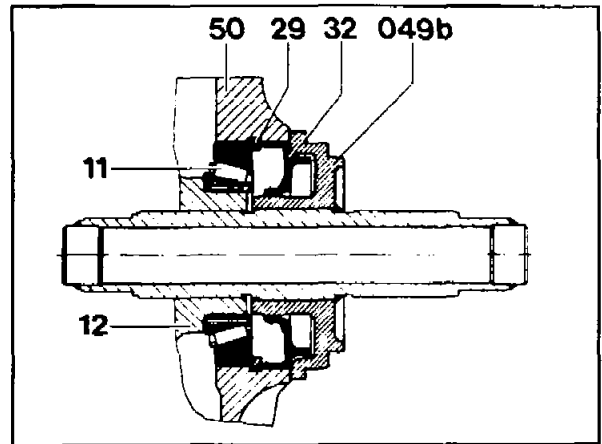

P35-5273-13

Press partially rubberized radial sealing rings (32) into ASR rear axle housing with drift punch (014a) 126 589 04 15 00. Coat sealing lip on radial sealing ring lightly with hypoid gear oil.

7 Install in reverse sequence.

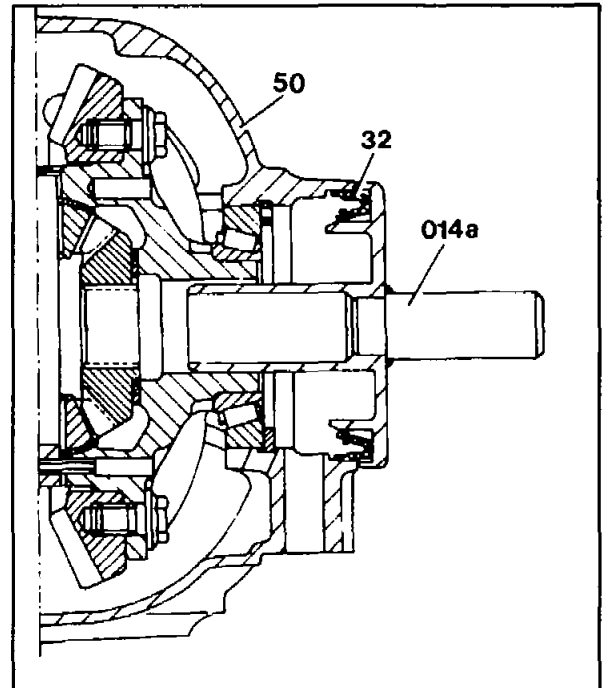

P35-5426-15

C. Rear axle center assembly with 210 mm dia. crown wheel

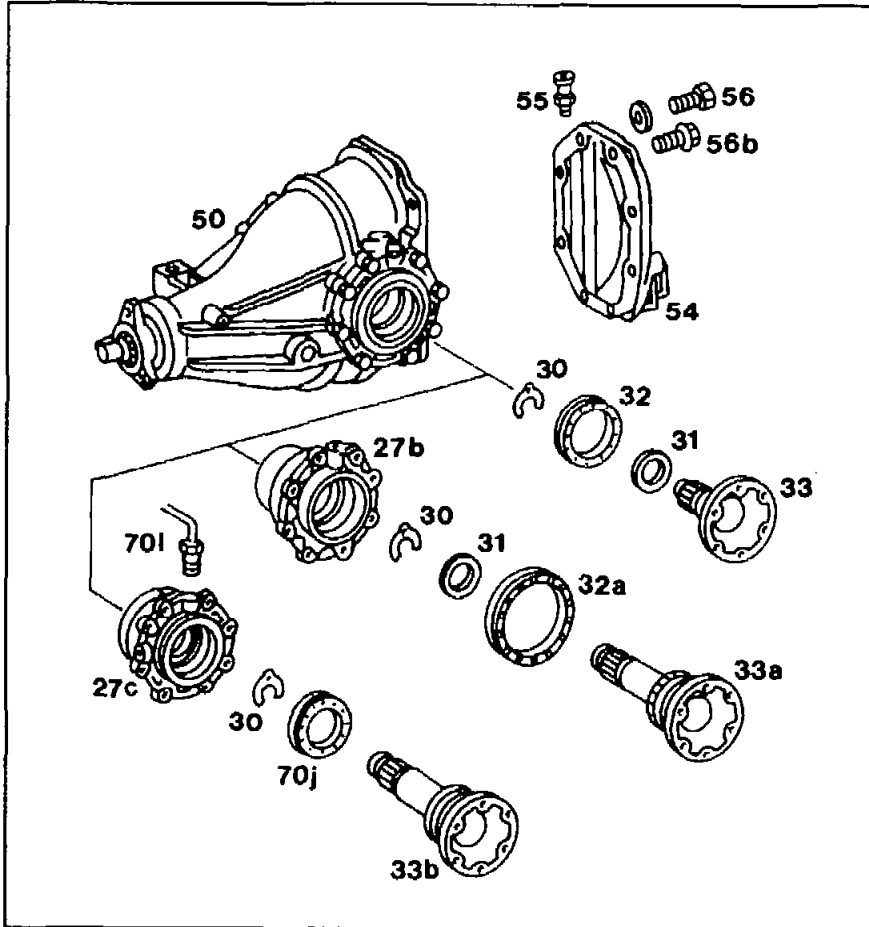

P35-5565-37

Rear axle oil	Drain, fill. Filling height up to lower edge of filler opening. Tightening torque 50 Nm (number 1).
Rear axle center assembly (50)	Clamp in clamping fixture 129 589 00 31 00 (number 2).
Rear axle closing plate (54)	Remove, install. Clean sealing surfaces and coat with sealing agent. Tightening torque of hexagon bolts (56) in strength class 8.8 = 45 Nm, 10.9 = 50 Nm, in the case of collar bolts (56b) = 55 Nm. Torque wrench 001 589 66 21 00 (number 3).
Rear axle breather (55)	Replace, tightening torque 25 Nm.
Cirdlips (30)	Remove, replace and install. Hook 116 589 01 62 00 (number 4).

Connecting flange (33, 33a, 33b) with spacer ring (31)

Remove, install. Adjust axial play of connecting flanges, apart from the rear axle center assembly with ASD (number 4).

On vehicles with ASD

Radial sealing ring (70j)

Pull out, replace and press in (number 5).
Removal fixture 129 589 02 33 00 section 04.
Pressing-in tool 124 589 01 15 00.

On vehicles with ASR or standard differential

Radial sealing ring (32, 32a)

Press out, replace and press in (number 6).
Pressing-in tool for: standard rear axle center assembly 140 589 06 15 00
ASR rear axle center assembly 126 589 04 15 00.

Special tools

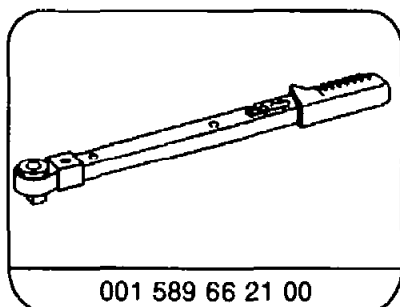
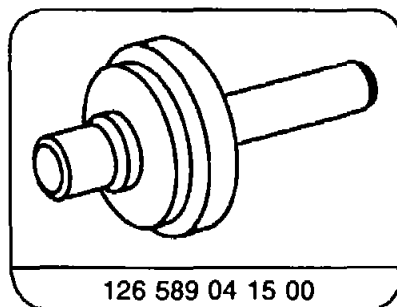
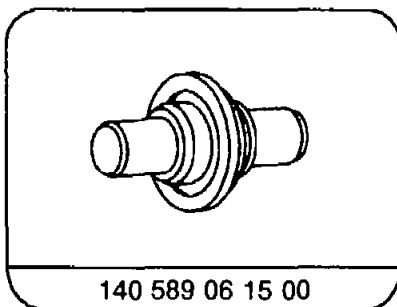
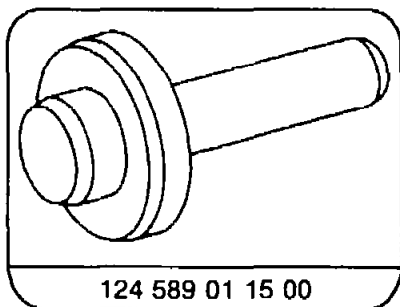
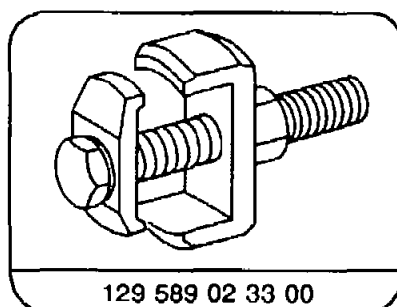
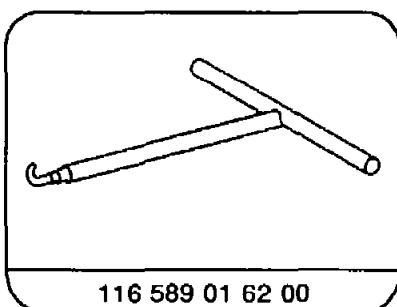
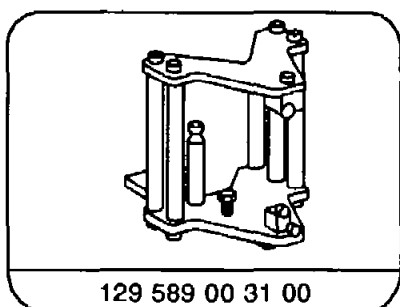

Spacer ring between inner constant-velocity joint and differential housing

Thickness	2.6–3.4 mm
Graduation	0.1 to 0.1 mm

Types of oil and capacity

Standard differential Differential with ASR	SAE 90 hypoid gear oil, refer to Specifications for Service Products, sheet no. 235
Differential with ASD	Special hypoid gear oil, refer to Specifications for Service Products, sheet no. 235.3
Capacity	1.3 liters

Removal, installation

- 1 Drain rear axle oil.

Installation note

The oil should come up to the bottom edge of the filler opening. For types of oil, refer to table "Types of oil and capacity". Tightening torque for plug 50 Nm.

- 2 Clamp rear axle center assembly in clamping fixture (054) 129 589 00 31 00 with locator section (054a) 129 589 00 31 00 section 15 and spacer (054b) 129 589 00 31 00 section 10.

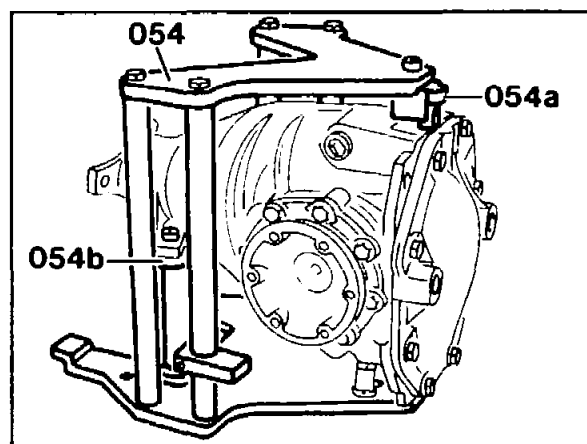

P35-5384-13

3 Remove rear axle closing plate (54) from rear axle housing.

Installation note

Replace rear axle vent and tighten to 25 Nm. Clean sealing surfaces on rear axle closing plate and rear axle center assembly and coat with sealing compound. Tightening torque for hexagon bolts (56) strength class 8.8 = 45 Nm, 10.9 = 50 Nm and for collar bolts 55 Nm. Torque wrench 001 589 66 21 00.

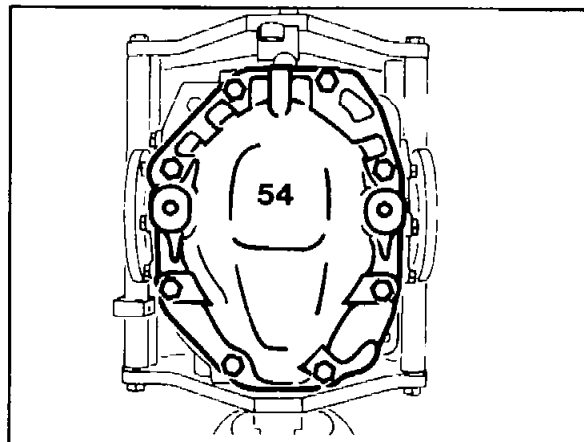

P35-5385-13

Rear axle closing plate - model 124

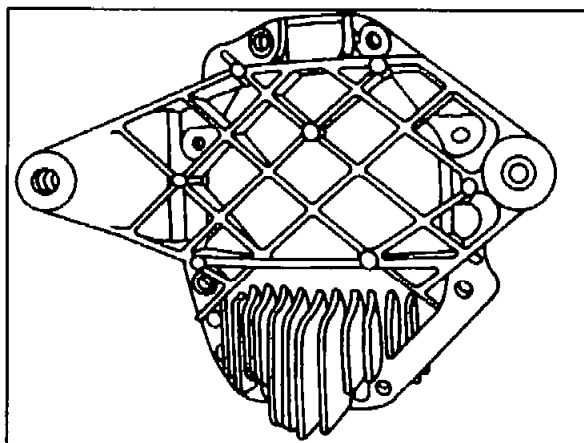

P35-5566-13

Rear axle closing plate
Models 124.034/036

4 Detach circlip (30) from connecting flange using hook 116 589 01 62 00. Remove connecting flange with spacer ring.

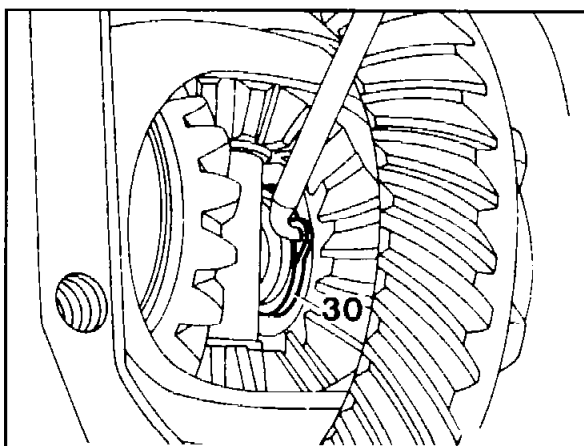

P35-5317-13

Installation note

Replace circlip, check axial play (except on vehicles with ASD). There should be no axial play; the circlip should still be able to turn in the groove. If required, use a thicker or thinner spacer ring (31).

ASR connecting flange

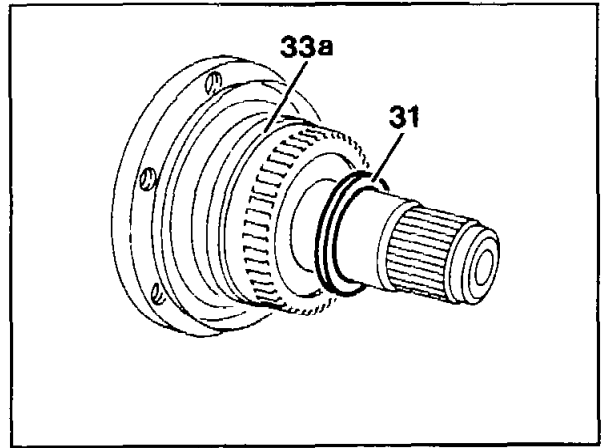

P35-5417-13

5 On vehicles with ASD

Using extractor (071) 129 589 02 33 00 section 04 pull radial sealing ring (70j) out of ring cylinder piston (70b).

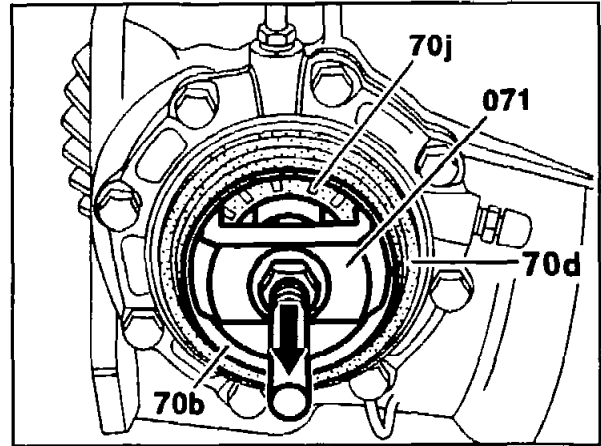

P35-5348-13

Installation note

Using pressing-in tool 124 589 01 15 00 press in radial sealing ring (70j). Lightly coat sealing lip with hypoid gear oil.

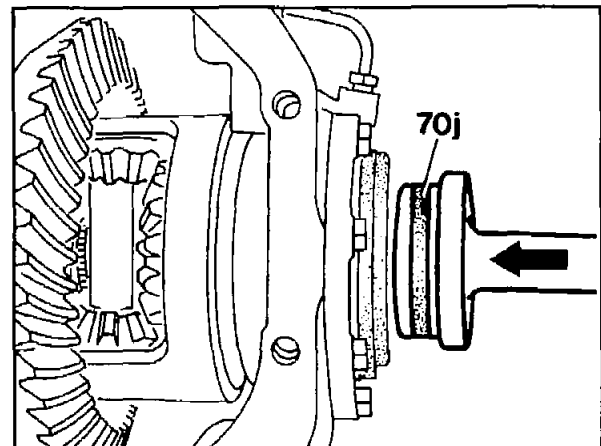

P35-5567-13

6 On vehicles with ASR or standard rear axle housing

Using screwdriver press radial sealing ring (32a) out of rear axle housing.

Location - ASR rear axle housing

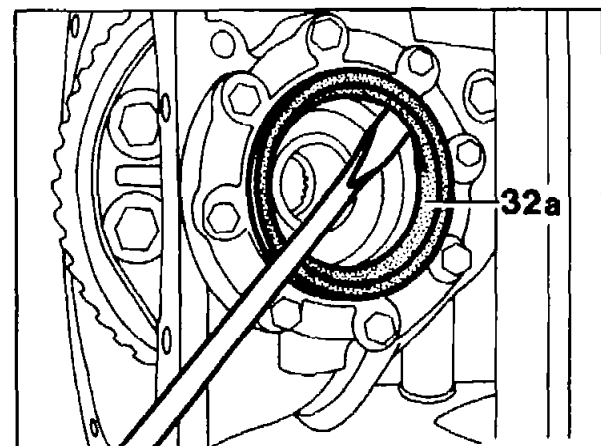

P35-5568-13

Installation note

Using pressing-in tool (032a) 140 589 06 15 00 in the case of standard rear axle housing and 126 589 04 15 00 in the case of ASR rear axle housing, press in radial sealing ring (32). Lightly coat sealing lip of sealing ring with hypoid gear oil.

Location - standard rear axle housing

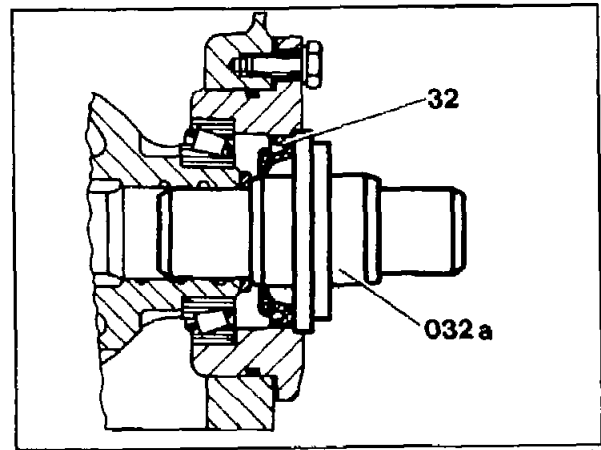

P35-5710-13

Location - ASR rear axle housing

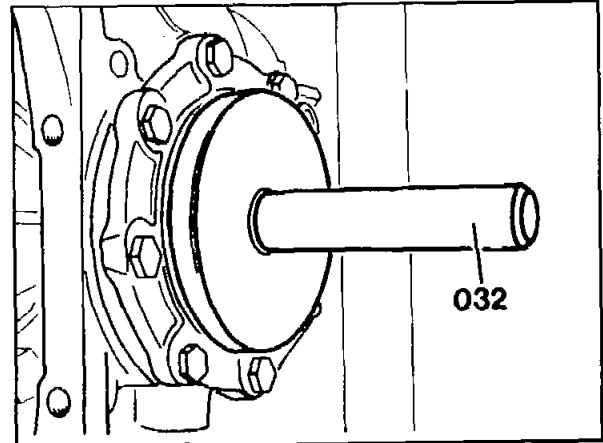

P35-2080-13

7 Install in reverse sequence.