

41-200 Renewing centering sleeve

A. Models 114, 115, 116, 123 as well as models 107 and 126 up to 08/85

Lubricant

Centering sleeve, approx. 6 g per sleeve

refer to Specifications for Service Products page 266.2

Tightening torques

Self-locking hex. nuts for fastening flexible couplings

M 10

Nm

40

M 12

60

Special tool

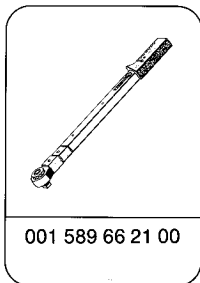

Note

In the event of wear or damage of sealing lip in centering sleeve (10) of front or rear propeller shaft, the centering sleeve can be individually replaced.

Removal

- 1 Remove propeller shaft (41-050).

Propeller shafts with vibration damper

1st version

- 2 Screw out hex. socket screws (11) with self-locking hex. nuts (14).



Prior to removing vibration damper (20), mark vibration damper and three-legged flange in relation to each other.

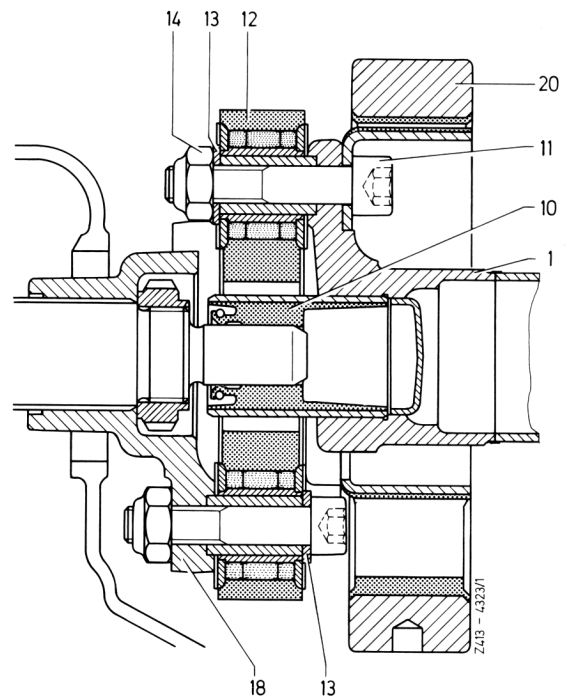

- 1 Front propeller shaft
- 10 Centering sleeve
- 11 Hex. socket screw
- 12 Flexible coupling
- 13 Washer
- 14 Self-locking hex. nut
- 18 Transmission universal flange
- 20 Vibration damper

Propeller shafts with vibration damper

2nd version

- 3 Unscrew hex. socket screws with self-locking hex. nuts. This version has an identification mark on three-legged flange (hump) and on vibration damper (vulcanized arrow).

- 4 Slide vibration damper back on front propeller shaft.



Propeller shafts without vibration damper

5 Mark flexible coupling in relation to three-legged flange of propeller shaft and remove.

Note

On radially or tangentially soft flexible couplings loosen the fitted sleeves vulcanized to three-legged flange. For this purpose, use a cylindrical mandrel of 10 mm dia. and approx. 150 mm in length.

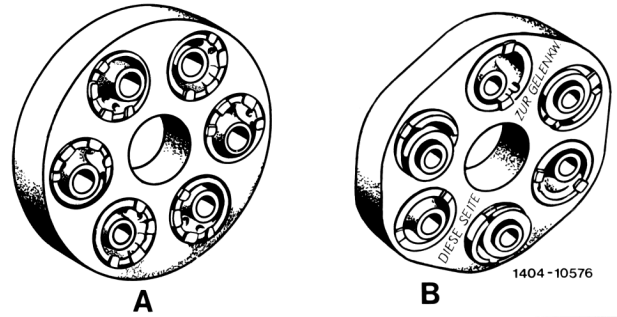

- A Soft push flexible coupling (radially)
- B Soft pull-push flexible coupling (tangentially)

Vehicles up to 07/82

6 During separation of front and rear propeller shaft, mark parts in relation to each other (arrows).

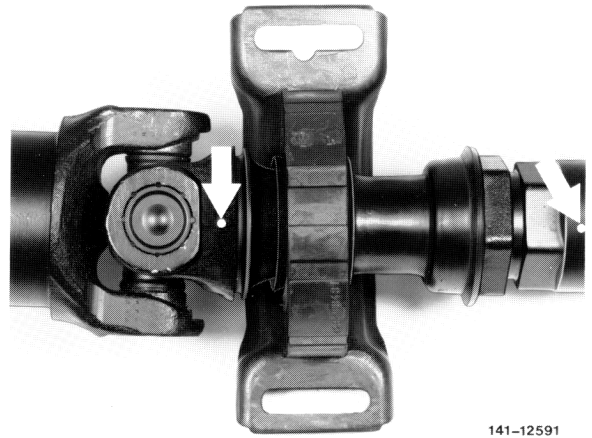

Vehicles starting 08/82

7 During a separation of front and rear propeller shaft the parts are marked in relation to each other (arrows).

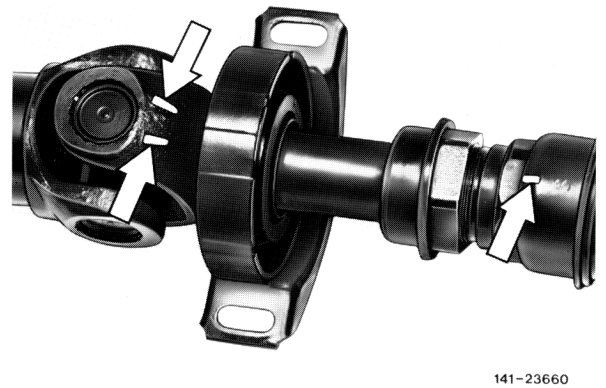

8 Drill a hole of approx. 10 mm dia. at a right angle through sleeve 15 mm from face of centering sleeve (10).

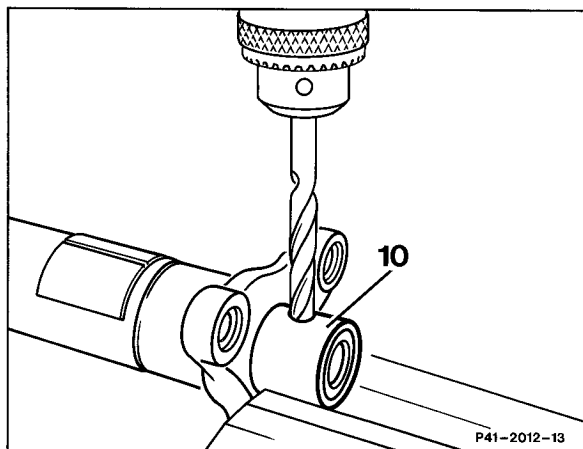

9 Slip a mandrel through bore and pull centering sleeve (10) out of propeller shaft by means of two mounting levers.

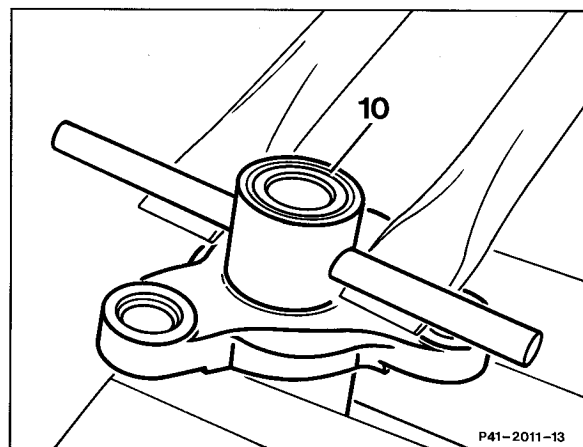

Installation

10 Press-in new centering sleeve up to thrust collar by means of a suitable mandrel (arrows).

Models 114, 115, 116, 123 and 107, 126.03/04/1 up to 08/85

Centering sleeve for front propeller shaft with hard flexible coupling and for rear propeller shaft.

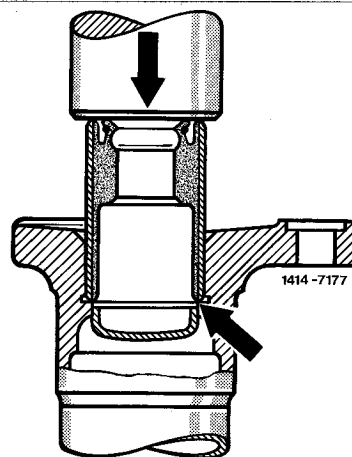

Model 126.02 and vehicles with manual 5-speed transmission up to 08/85

Centering sleeve for front propeller shaft with soft push flexible coupling or soft pull-push flexible coupling.

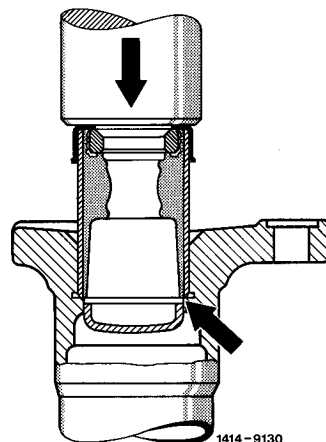

11 Grease cavity (arrow) of centering sleeve with specified grease (refer to Specifications for Service Products page 266.2), quantity per sleeve approx. 6 g.



Propeller shafts with vibration damper

12 Mount vibration damper and flexible coupling with hex. socket screws.

Tightening torque of self-locking hexagon nuts 40 Nm.



Pay attention to applied or existing identification prior to disassembly (arrow). Renew self-locking hex. nuts.

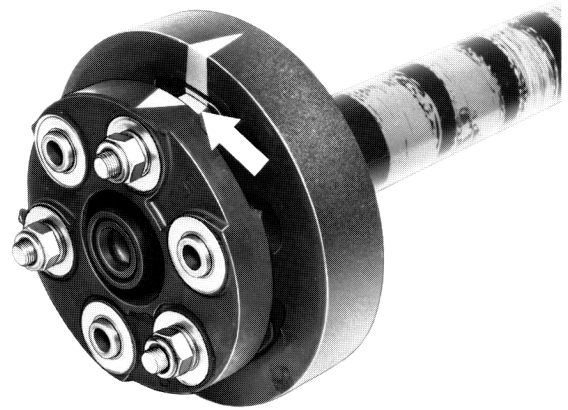

Identification in place

141 - 10859

The installation position is correct if the vulcanized arrow of vibration damper points to hump of three-legged flange (identification in place).

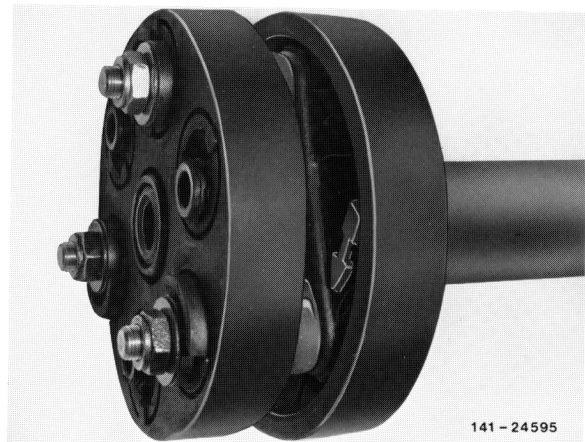

Identification in place

141 - 24595

Propeller shafts without vibration damper

13 Mount flexible coupling as shown, tightening torque of self-locking hex. nuts M 10 = 40 Nm,
M 12 = 60 Nm.

Note

Renew self-locking hex. nuts.



14 Mount soft pull-push flexible coupling (on vehicles with 5-speed transmission) according to lettering "DIESE SEITE ZUR GELENKWELLE" (THIS SIDE TOWARD PROPELLER SHAFT).

15 Install propeller shaft (41-050).



B Models 107 and 126 starting 09/85

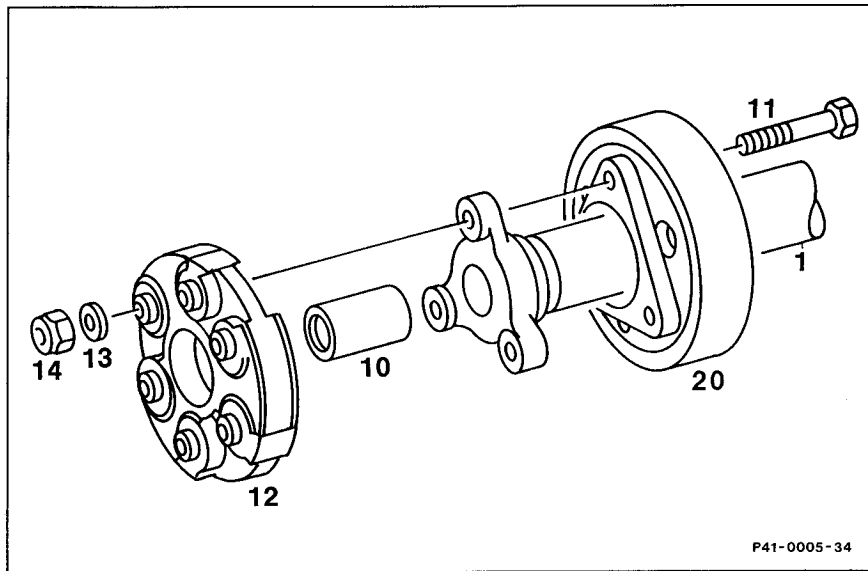

- Propeller shaft remove and install (41-050).

- Hex. head screws (11) Unscrew, screw on, M 10 = 40 Nm, M 12 = 60 Nm.
Replace self-locking hexagon nuts (14).

- Flexible coupling (12) and vibration damper (20) mount and remove. Mark vibration damper and flexible coupling in relation to propeller shaft. Loosen fitted sleeves with 10 mm dia. mandrel (items 4, 5).

- Centering sleeve (10) pull out of propeller shaft, press-in. Pay attention to pressing-in dimensions. With plastic bushings, grease cavity with Molykote grease and use multi-purpose grease with multi-component bushings (refer to Specifications for Service Products, page 266.2 and 267, quantity per sleeve approx. 6 g).

Pressing-in dimensions of centering sleeve

Model	Dimension "a" from end face of centering sleeve to three-legged flange in mm	
	front	rear
107.041, 126.02	30	24,9
107.046/047/048 126.03/04/1	20.4	23.9

Special tool

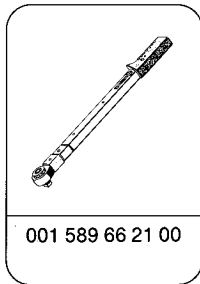

001 589 66 21 00

Note

In the event of wear or damage to sealing lip in centering sleeve (10) of front or rear propeller shaft, the centering sleeve can be individually replaced.

- 1 Front propeller shaft
- 10 Centering sleeve
- 11 Hex. socket screw
- 12 Flexible coupling
- 13 Washer
- 14 Self-locking hex. nut
- 18 Transmission universal flange
- 20 Vibration damper

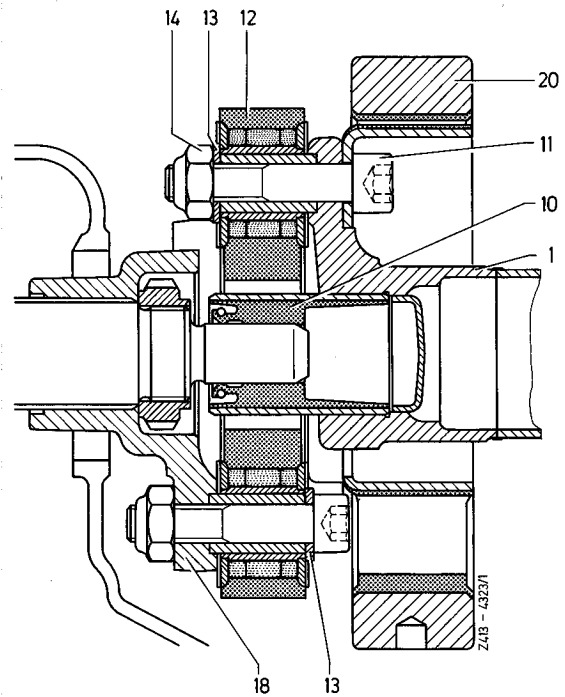

Removal and installation

- 1 Remove propeller shaft (41-050).
- 2 Unscrew hex. head screws with self-locking hex. nuts.

Propeller shafts without vibration damper

- 3 On this version, mark flexible coupling (arrow) in relation to three-legged flange of propeller shaft.

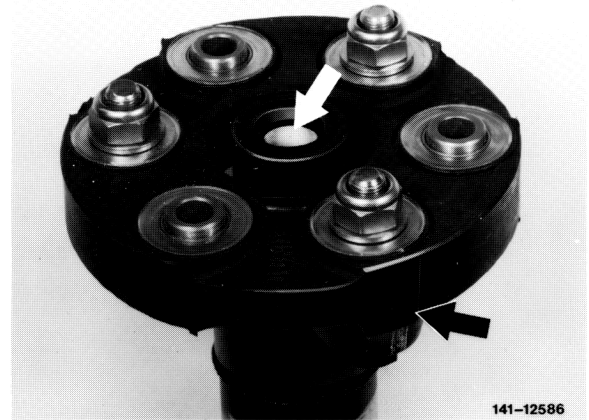

Propeller shafts with vibration damper

- 4 On this version, an identification mark on three-legged flange (hump) and on vibration damper (20) (vulcanized arrow) is in place.

Note

The installation position is correct, when the arrow of vibration damper (20) points to hump of three-legged flange (arrows).

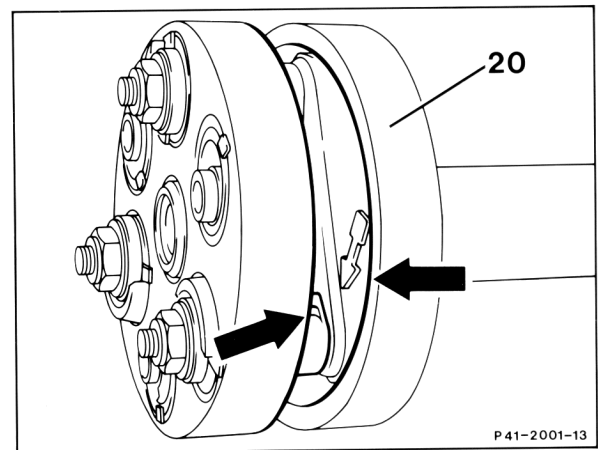

Installation note

Renew self-locking hex. nuts.

Tightening torque M 10 = 40 Nm,
 M 12 = 60 Nm.

Mount soft pull-push flexible coupling (on vehicles with engine 103) according to lettering "DIESE SEITE ZUR GELENKWELLE" (THIS SIDE TOWARD PROPELLER SHAFT).



5 On soft pull-push flexible coupling (tangentially soft) loosen the vulcanized fitted sleeves from three-legged flange. For this purpose, use a cylindrical mandrel of 10 mm dia. and approx. 150 mm in length.

6 Remove flexible coupling and, if installed, vibration damper.

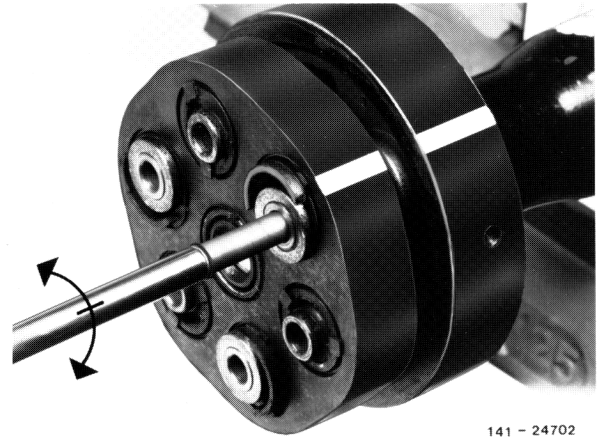

141 - 24702

7 Separate front propeller shaft from rear propeller shaft.

Installation note

Front and rear propeller shaft are marked in relation to each other. When joined, make sure that the hump on front propeller shaft is located in center of the two arrow-Modele humps of fork-Modele joint (arrows).

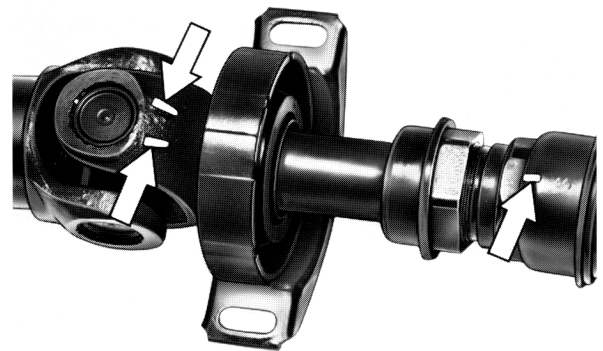

141 - 23660

Removing centering sleeve

8 At low pulling force:
Knock centering sleeve uniformly out of propeller shaft by means of a flat chisel (arrows).



141 - 24706

9 At high pulling force:

Drill an approx. 10 mm dia. hole at a right angle through sleeve 15 mm from face of centering sleeve.

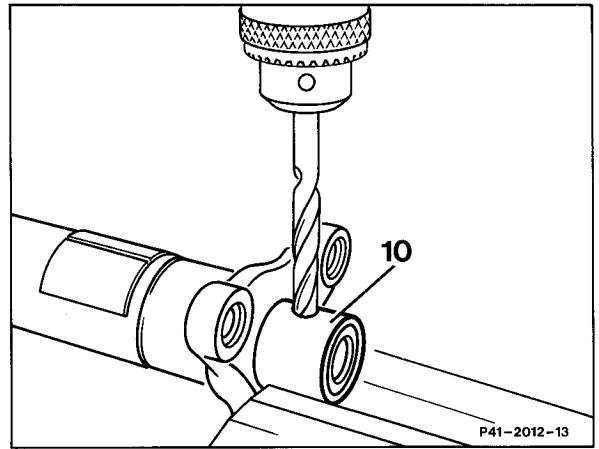

10 Insert a mandrel through bore and pull centering sleeve out of propeller shaft by means of two assembly levers.

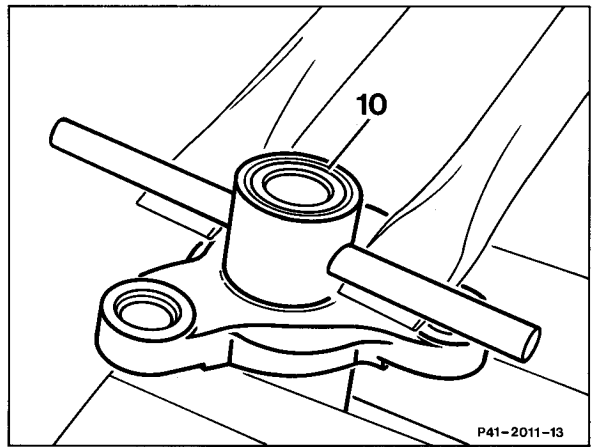

11 Press-in new centering sleeve with suitable mandrel. Pay attention to pressing-in dimension of centering sleeve (refer to table).

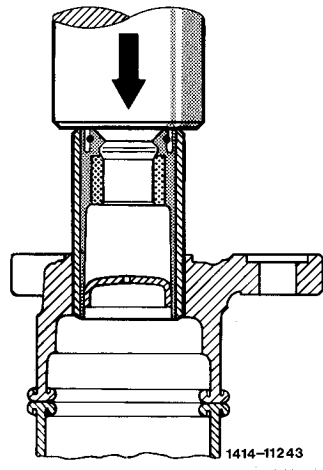

Model	Dimension "a" from face of centering sleeve to three-legged flange	
	front	rear
107.041 126.02	30	24.9
107.046/047 126.03/04 126.1	20.4	23.9

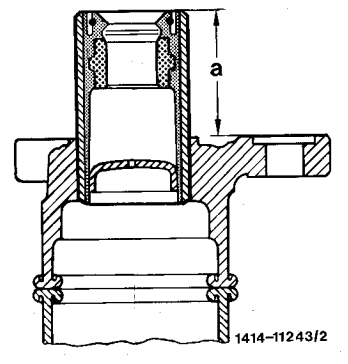

12 With bronze bushing, grease cavity of centering sleeve with Molykote grease and use multi-purpose grease with multi-component bushing (refer to Specifications for Service Products page 266.2 and 267, quantity per sleeve approx. 6 g).

13 For further installation proceed vice versa as of item 7.

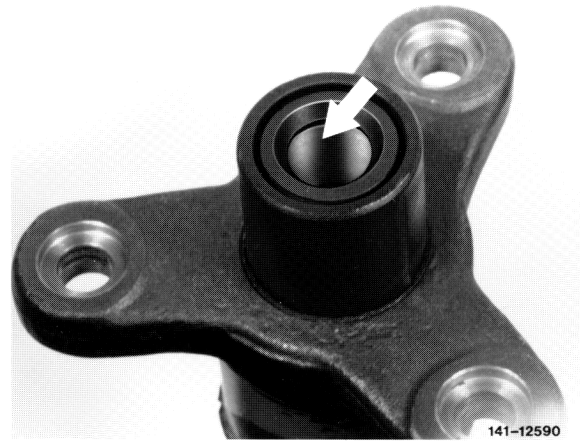

C. Models 124, 201

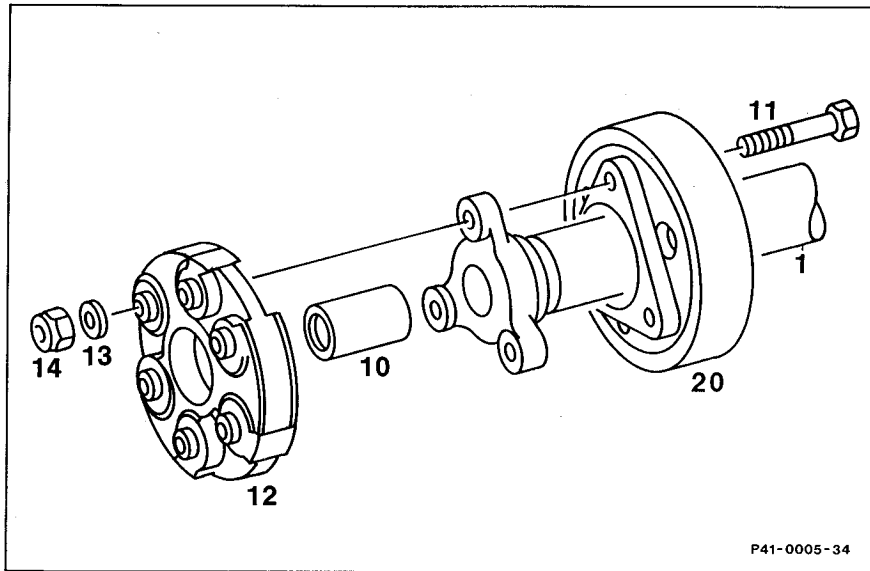

- | | |
|---|--|
| <p>Propeller shaft</p> <p>Hex. head screws (11)</p> <p>Flexible coupling (12) and vibration damper (20),
if applicable</p> <p>Centering sleeve (10)</p> | <p>Remove and install (41-050).
 Unscrew and screw on, M 10 = 40 Nm,
 M 12 = 60 Nm.</p> <p>Unscrew and screw on, M 10 = 40 Nm,
 M 12 = 60 Nm.</p> <p>Renew self-locking hex. nuts (14).</p> <p>remove and mount. Mark vibration damper and
flexible coupling in relation to propeller shaft.
Loosen vulcanized fitted sleeves with 10 mm
dia. mandrel (items 1, 2).</p> <p>pull out of propeller shaft, press-in.
Pay attention to pressing-in dimensions. With
bronze bushings, grease cavity with Molykote
grease and use multi-purpose grease with multi-
component bushings (refer to Specifications for
Service Products, page 266.2 and 267, quantity
per sleeve approx. 6 g).</p> |
|---|--|

Centering sleeve

Model	Dimension "a" from end face of centering sleeve to three-legged flange up to 08/89	
	front	rear
124.00 124.023/026/030 124.043/050/083/090 124.128/130/190/2/330 201.028/029/128	30	24.9
124.133/193	20.4	23.9
124.020/021/080/081 124.105/106/120 ¹⁾ /125 124.180 ¹⁾ /185 201.023/024/122 ¹⁾ /126	32.5	
124.333/393	-	
201.035/036	24.9	

1) With automatic transmission, front dimension "a" 30.5.

Centering sleeve

Model	Dimension "a" from end face of centering sleeve to three-legged flange as of 09/89 with introduction of dual-mass flywheel and as of 03/89 with bolt circle dia. changed from 80 mm to 90 mm			
	front		rear	
	manual transmission	automatic transmission	manual transmission	automatic transmission
124.00 124.023/026 ¹⁾ /030 ¹⁾ 124.042/043/062/050 ¹⁾ 124.083/090 ¹⁾ 124.127/2 201.028/029/128	24.9	30	24.9	
124.020/021/041/080 124.081 124.104/105/106 124.180 201.023/024 201.122/126	30		24.9	
124.031/051/091	25.7		25.6	
124.130 ²⁾ /190 ²⁾ /330	30		24.9	
124.133/193	-	20.4	23.9	
124.333/393	-		23.9	
124.032/092 124.052/066	25.7			

Centering sleeve

Model	Dimension "a" from end face of centering sleeve to three-legged flange as of 09/89 with introduction of dual-mass flywheel and as of 03/89 with bolt circle dia. changed from 80 mm to 90 mm			
	front		rear	
	manual transmission	automatic transmission	manual transmission	automatic transmission
124.034/036	–	22.4	25.9	
201.018	30	24.9	24.9	
124.027 201.035/036	24.9			

1) With bolt circle dia. of 100 mm and automatic transmission front dimension "a" 31 mm.

2) Taxi version front dimension "a" 24.9 mm.

Centering sleeve

Model	Dimension "a" from end face of centering sleeve to three-legged flange						
	front		Air	Taxi		rear	Taxi
	MT	AT	conditioner	MT	AT	MT/AT	AST
124.019/079	30.0		24.9	24.9		24.9	
124.022/083	24.9	30.0	–	–	24.9	24.9	
124.028/088	33.5	25.7	–	25.7	–	25.7	
124.120/125/185	30.0		–	24.9		24.9	
124.128/188	24.9	30.0	–	30.0	24.9	24.9	
124.131/191	30.0		–	24.9		24.9	
124.040/060	30.0		24.9	–		24.9	

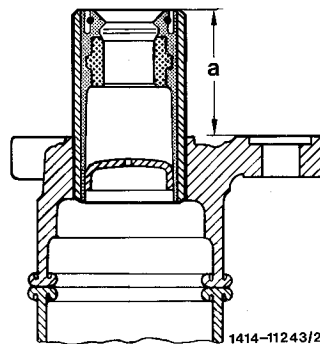

Dimension "a" measured from end face of centering sleeve three-legged flange

Special tool

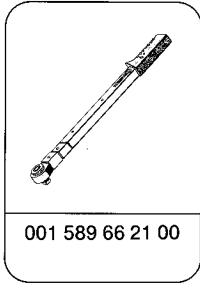

001 589 66 21 00

Note

In the event of wear or damage to sealing lip in centering sleeve (10) of front or rear propeller shaft, the centering sleeve can be individually replaced.

Layout with flexible coupling and 80 mm bolt circle dia.

- 1 Front propeller shaft
- 10 Centering sleeve
- 11 Hex. socket screw
- 12 Flexible coupling standard version
- 12b Centering bushing
- 13 Washer
- 14 Self-locking hex. nut
- 18 Transmission universal flange
- 20 Vibration damper

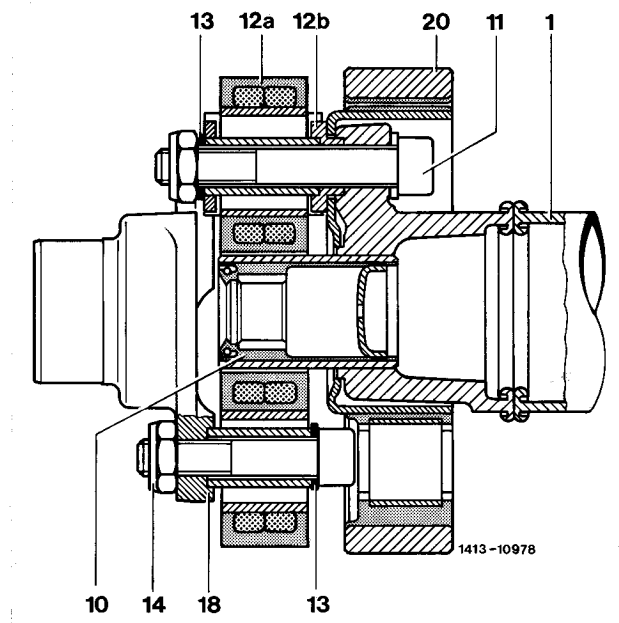

Layout with flexible coupling and 90 mm bolt circle dia.

- 1 Front propeller shaft
- 10 Centering sleeve
- 11 Hex. head screw
- 12a Flexible coupling
- 12c Disks firmly connected to sleeve
- 13 Washer
- 14 Self-locking hex. nut
- 18 Transmission universal flange
- 20 Vibration damper

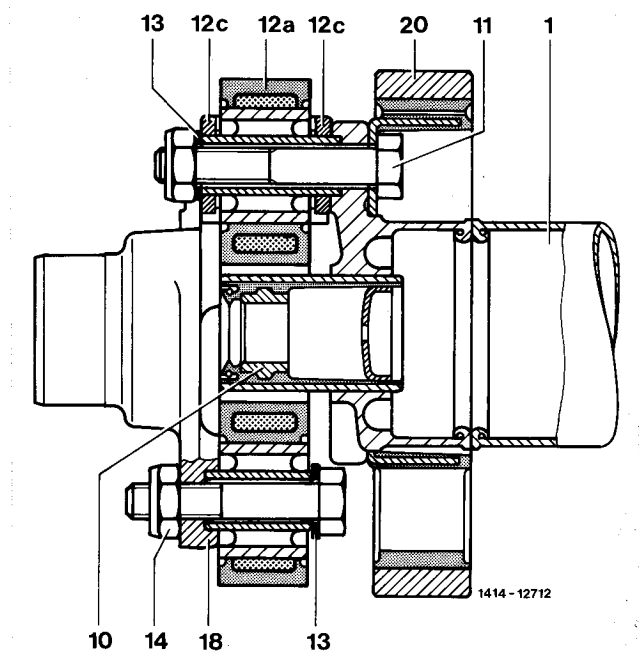

Removal and installation

- 1 Remove propeller shaft (41-050).
- 2 Unscrew hex. socket or hex. head screws with self-locking hex. nuts.

Installation note

The installation position is correct, if the vulcanized arrow on vibration damper points to hump of three-legged flange (arrows).

Renew self-locking hex. nuts.

Tightening torque M 10 = 45 Nm,
 M 12 = 65 Nm.

Marking on 1st version up to 12/89

Arrangement with 90 mm bolt circle dia. and vibration damper mounted from the back

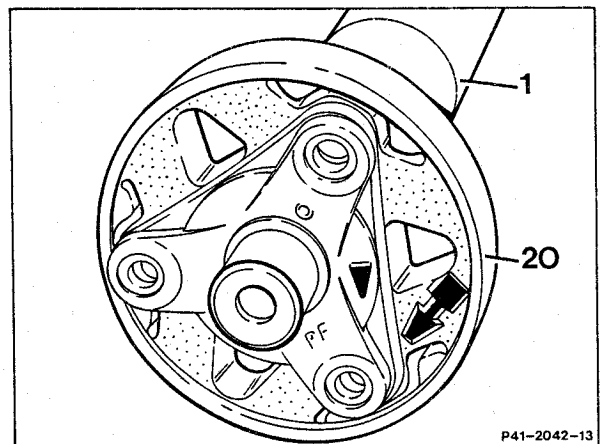
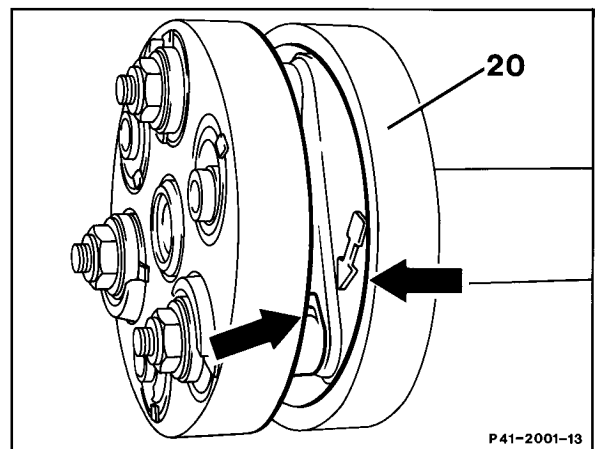

Marking on 2nd version as of 01/90

Arrangement with 90 mm bolt circle dia. and vibration damper mounted from the back

Arrangement on model 124 with 80, 90, 100 and 110 mm bolt circle dia. and hard flexible coupling

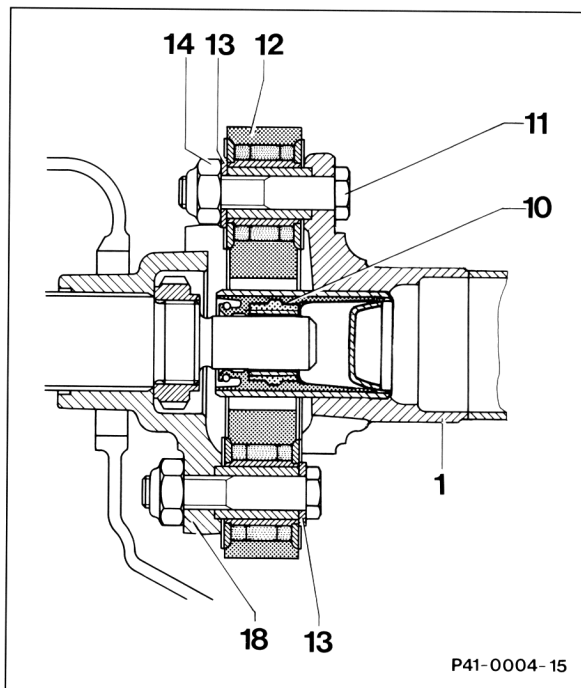

Installation note

The installation position is correct, if the vulcanized arrow on vibration damper behind hump is mounted on three-legged flange (cutouts). Replace self-locking hexagon nuts; Tightening torque 40 Nm.

3 On propeller shafts without vibration damper, be sure to mark the flexible coupling in relation to three-legged flange of propeller shaft.

Arrangement with 80 mm bolt circle dia. and vibration damper mounted from the front

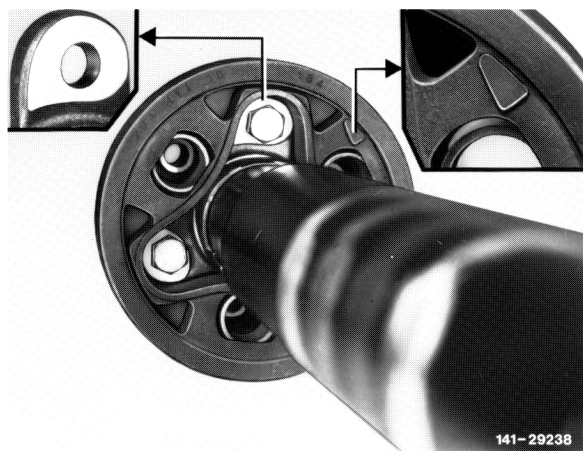

4 Soft pull-push flexible coupling (soft pull-push) according to lettering "DIESE SEITE ZUR GELENKWELLE" (THIS SIDE TOWARD PROPELLER SHAFT).



5 On vehicles with soft pull-push flexible coupling (soft pull-push) loosen the vulcanized fitted sleeves out of three-legged flange. For this purpose, use a cylindrical mandrel of 10 mm dia. and approx. 150 mm in length.

6 Remove flexible coupling and, if installed, vibration damper.

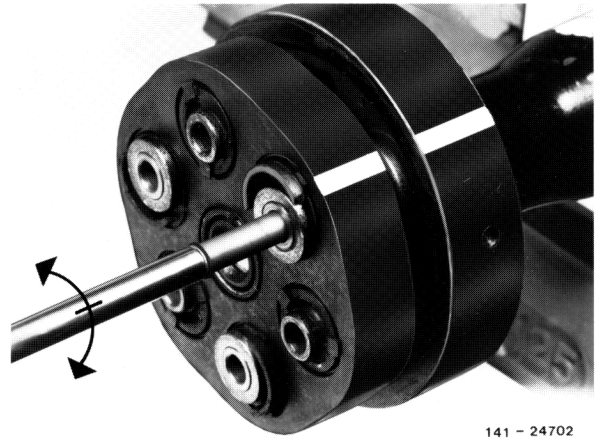

141 - 24702

7 Separate front propeller shaft from rear propeller shaft.

Installation note

Front and rear propeller shaft are marked in relation to each other. When joined, make sure that the hump on front propeller shaft is located in center of the two arrow-Modele humps of fork-Modele joint (arrows).

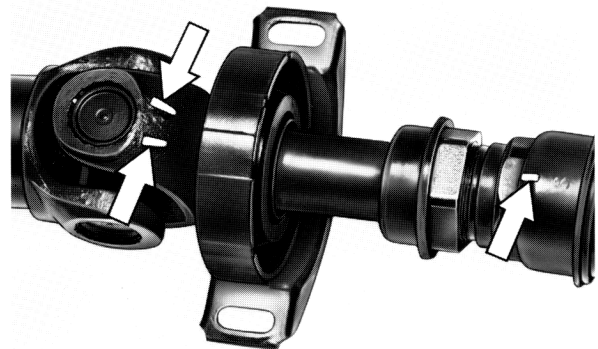

141 - 23660

Removing centering sleeves

8 At low pulling force:
Knock centering sleeve uniformly out of propeller shaft by means of a flat chisel (arrows).

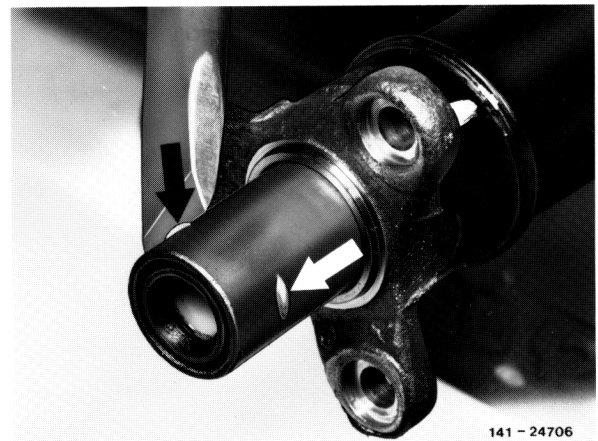

141 - 24706

9 At high pulling force:
Drill an approx. 10 mm dia. hole at a right angle through sleeve 15 mm from face of centering sleeve.

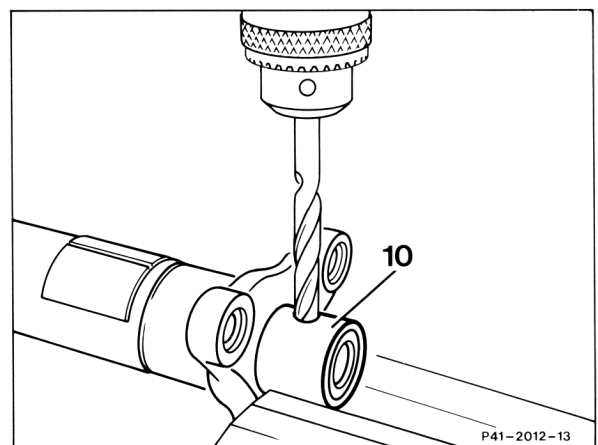

10 Insert a mandrel through bore and pull centering sleeve out of propeller shaft by means of two assembly levers.

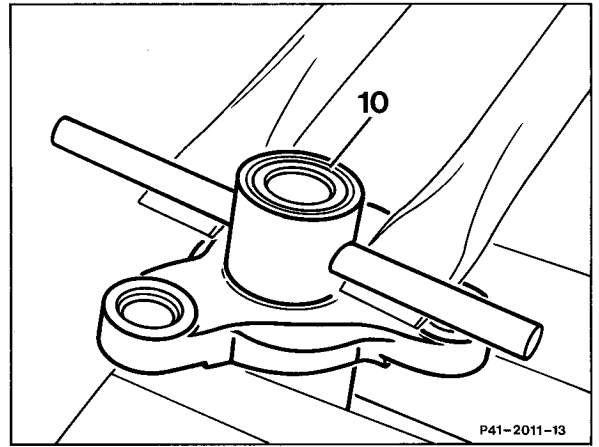

Installation note

Press-in new centering sleeve with suitable mandrel. Pay attention to pressing-in dimension of centering sleeve (refer to table for pressing-in dimensions for centering sleeve).

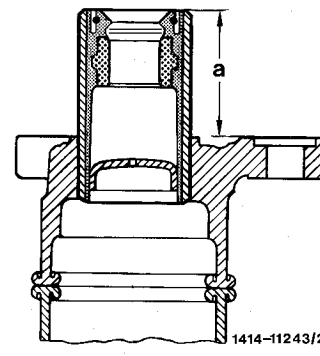
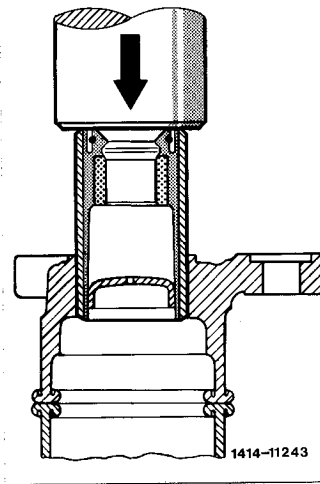

Dimension "a" measured from end face of centering sleeve to three-legged flange



11 With plastic bushing, grease cavity of centering sleeve with Molykote grease and use multi-purpose grease with multi-component bushing (refer to Specifications for Service Products page 266.2 and 267, filling capacity per sleeve approx. 6 g).

12 For further installation proceed vice versa as of item 6.

