

46-0120 Checking and adjusting friction torque of steering gear

Preceding work:
Removing and installing steering gear (46-3400)

Operation no. of operation texts and work units or standard texts
and flat rates
46-3230

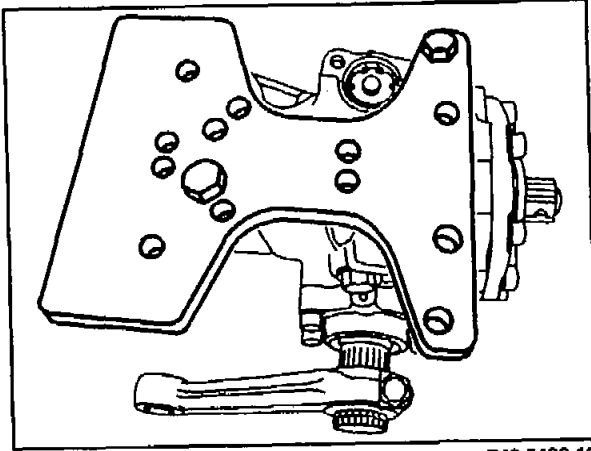

P46-5480-13

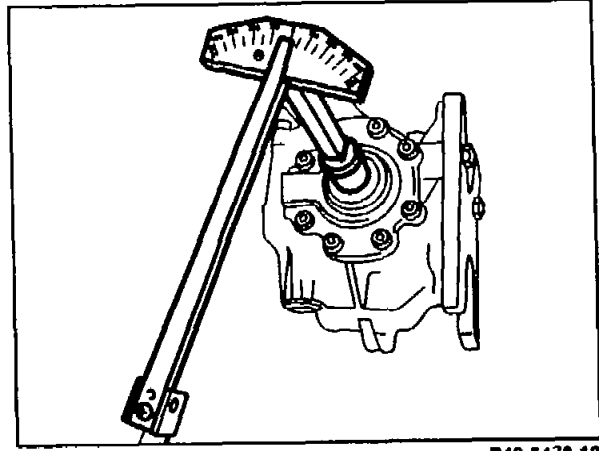

P46-5478-13

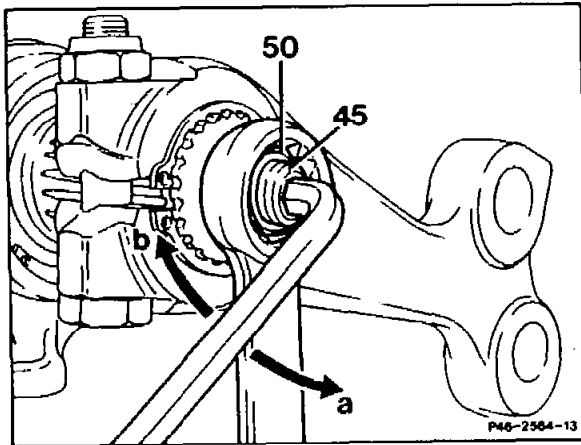

P46-2564-13

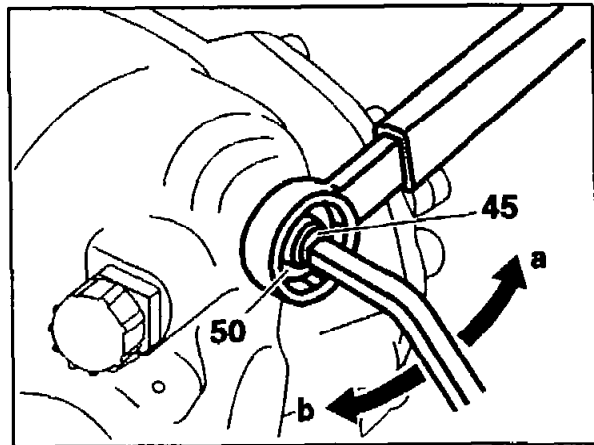

P46-5433-13

Steering gear
Total friction torque

mount on assembly support 140 589 00 59 00
with two screws and clamp in the vise.
measure at steering shaft with
friction torquemeter 123 589 02 21 00 and
wrench socket insert 123 589 00 08 00 by
slowly turning the steering shaft from stop
to stop several times.

Lock nut (50)

slacken. Turn adjusting screw (45) 1/4 turn in stages

- direction "a" = increases friction torque
- direction "b" = reduces friction torque

Tighten collar nut to 60–65 Nm, holding adjusting screw (45) tight.

Total friction torque

re-check after tightening collar nut.

Observe notes

The friction torque in the center area should be 30–60 Ncm above the previously measured basic friction torque.

Example:

Friction torque of steering gear after setting	
Basic friction torque	60 Ncm
Increase in center area	30–60 Ncm
Total friction torque	90–120 Ncm

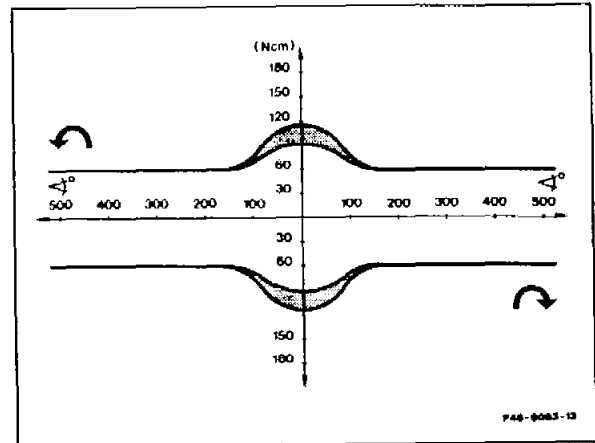

Set value

When the steering shaft is over the center position, the total friction torque should be

New steering	110–150 Ncm
Used steering	100–120 Ncm

Special tools

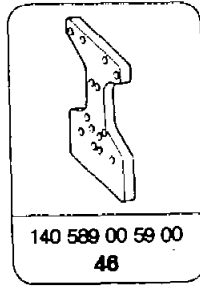
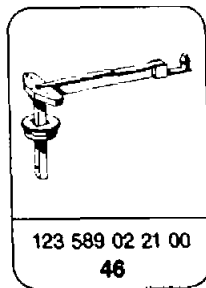
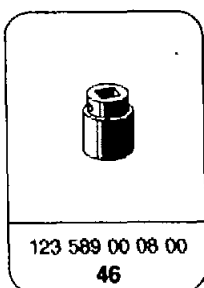

Notes

The steering gears are equipped with play compensation. However, this only acts in the center range of the steering gear.

An adjustment can therefore only be carried out noting the following points:

1. Do not adjust friction moment above the specified value.
2. When turning the steering gear no high spots should be detected after adjustment.
3. The steering must self-center correctly when driving straight ahead on a test drive.

On steering gears 765.900 (model 201 up to vehicle chassis end no. A 084024) the clamping bush (83) must be detached to adjust the friction moment. After adjusting the friction moment, push the clamping bush (83) onto the steering shaft so that both surfaces are parallel to the mounting points of the steering gear and the milled section points towards the pitman arm (arrow).

Push on support ring (84) and tighten the nut (85) to 50 Nm.

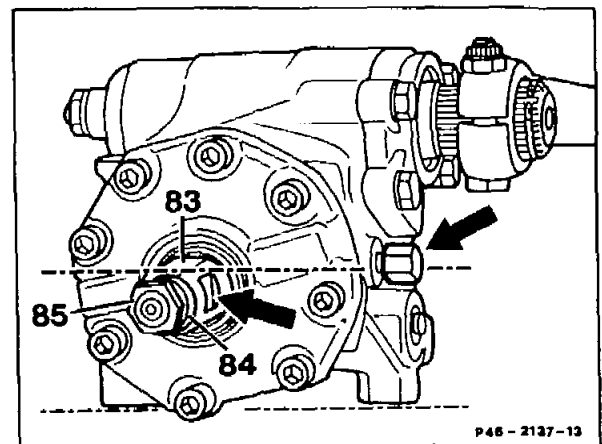

On steering gears 765.922 and 765.950 (model 202), the sleeve (23j) with two surfaces be detached from the steering shaft.

After adjusting the friction moment first

- align the clamping slot of the sleeve (23j) of the marking notch of the steering shaft, then
- push on sleeve (23j) up to the stop on the steering shaft and secure with new locking ring (23i).

