

67-100 Removal and installation of windshield glass

Note:

Remove scratches in glass by polishing, refer to

SI 67/18

Road metal, possible repairs, refer to SI 67/13A

A. Sedan and T-sedan

Special tools

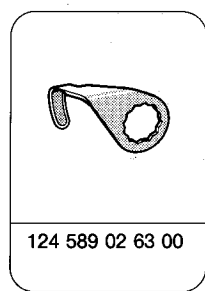
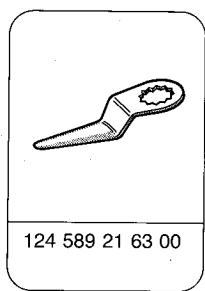
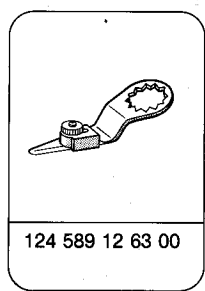

Conventional tools

e.g. Company, Order no.

Multi-cutter

Chicago Pneumatic
D-65366 Geisenheim
CP 838-12

Suction lifter

Karl Assfalg KG, Buchstraße 149
D-73525 Schwäbisch Gmünd
602-2

Electric gun with battery

Weiler & Co.
Postfach 1269
D-76287 Rheinstetten, Baden
Pressofix 108, Electronic, SDF-108 E

Parts

Repair pack for glazing
windshield or back window glass

124 670 01 93

Scope

- 1 Coating brush
- 2 Glass primer
- 3 Glass activator (cleaner)
- 4 Betaseal glueing material 150 ml
- 5 Coating nozzles
- 6 Cutting wire, spacing blocks, spacing angles, spacing rubber and cleaning cloth
- 7 Betaseal glueing material 300 ml

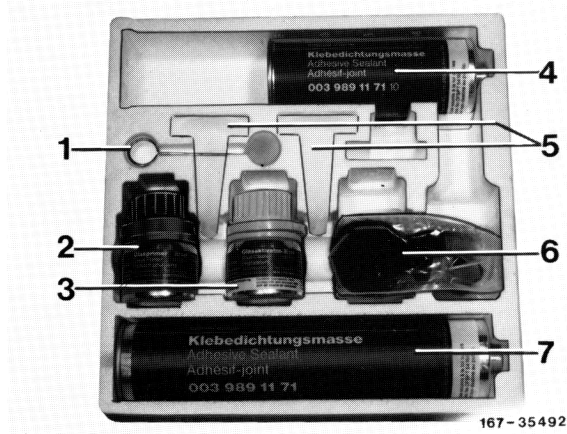

Removal

- 1 Open engine hood and set vertically.
- 2 Tape both front fenders in rear range with adhesive tape and additionally mount protective fender covers.
- 3 Remove wiper system (Group 82).
- 4 Pull water deflector left and right in range of front wall pillar out of holding clips and locate with rubber straps on outside mirrors.
- 5 Push out trimstrip at top with assembly wedge.

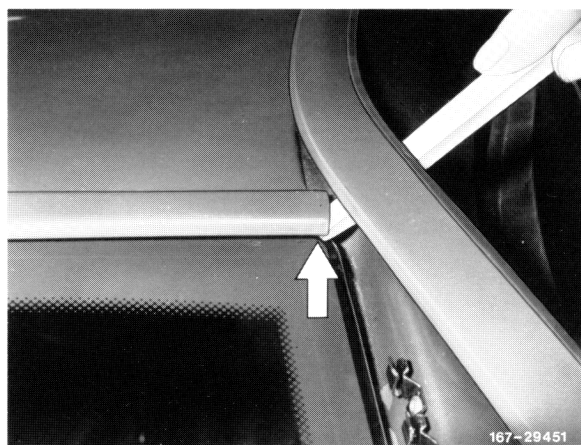

6 Remove glass support below and put away for safekeeping.

1st version: Unscrew screw or nut.

a = Glass
b = Angle bracket

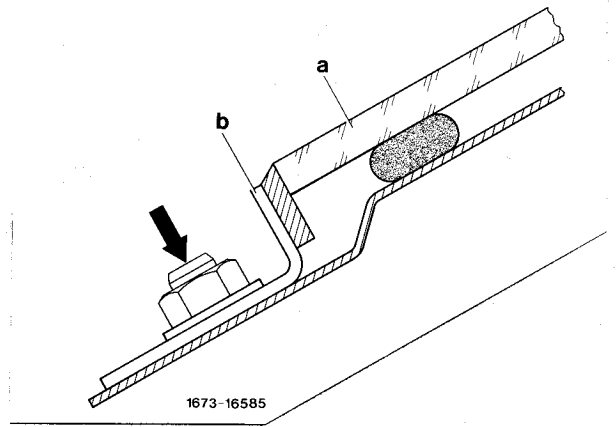

2nd version: Push pin (arrow) of angle bracket, push bracket down and unclip.

a = Glass
b = Angle bracket

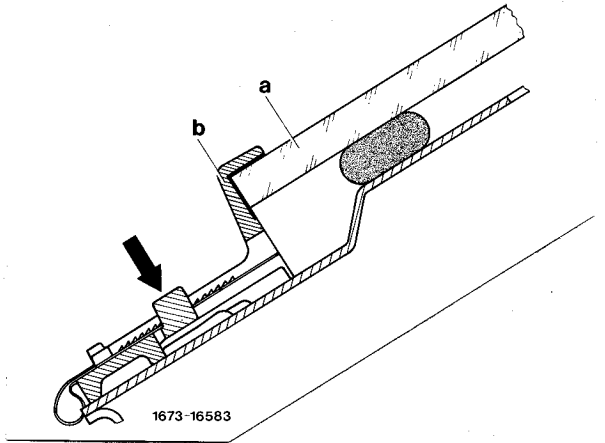

3rd version: Holding strips (not visible) are separated when glass is removed.

a = Glass
b = Holding strip

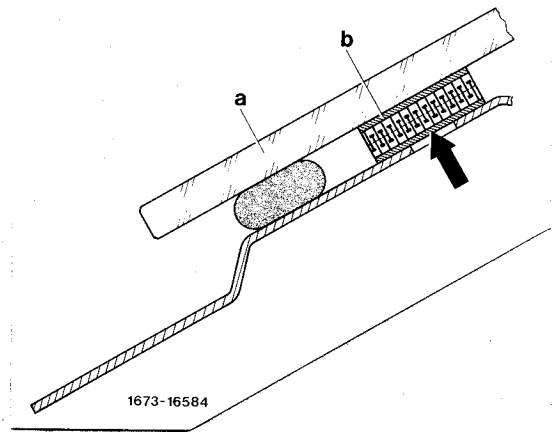

7 Let a second mechanic remove screws at left and right of engine hood (do not disconnect electric connections and hoses on windshield washer nozzles).

8 Raise engine hood vertically over hinges and put down horizontally in front of hinges on protective fender covers.

9 Mark location of clips with a felt pin on glass, so that the multi-cutter in range of clips can be slightly pulled back when glueing bead is cut through.

10 Remove reveal molding on windshield at top and laterally (68-400 and 68-405).

11 Locate multi-cutter available for use (air supply interrupted).

12 Clamp knife no. 1 into multi-cutter and set stop as required (dimension $a = 18 \text{ mm}$).

13 Moisten oil stone, connect air supply and sharpen both sides of knife with machine switched on.

14 Switch off multi-cutter.

Attention!

Wear goggles.

15 Move into working position (right-handers on front passenger seat, left-handers on driver's seat).

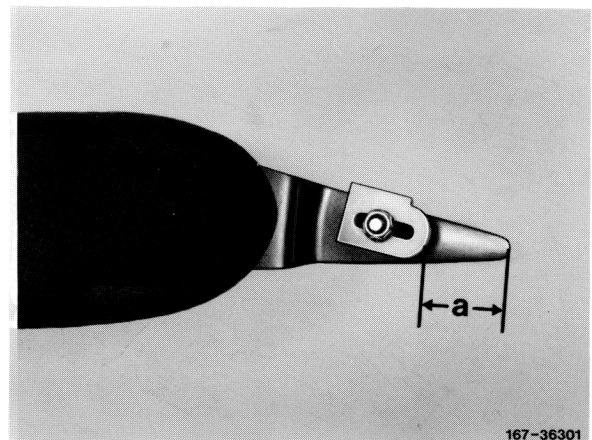
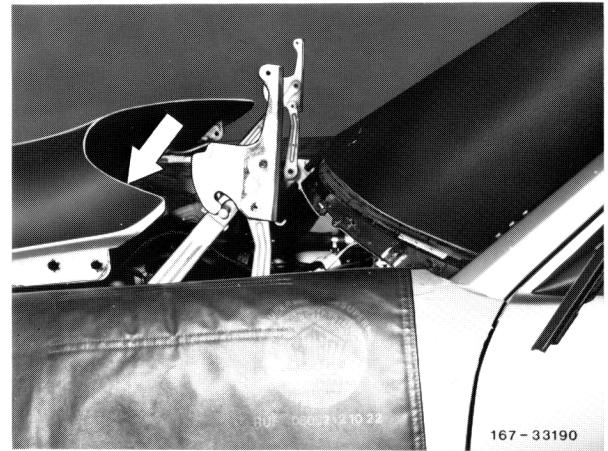

16 Switch on multi-cutter, plunge-cut with knife at starting point "A" and cut through adhesive bead, guiding knife in parallel with glass, in upward direction toward vehicle center.

Note: Slightly pull back multi-cutter in range of upper clips (mark).

17 Switch off multi-cutter.

18 Change operating position and cut through bead on other side.

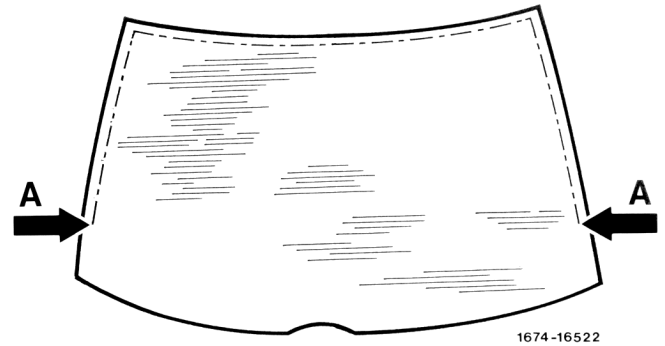

19 Switch off multi-cutter (air supply interrupted), change knife no. 1 for knife no. 2 and sharpen (item 13).

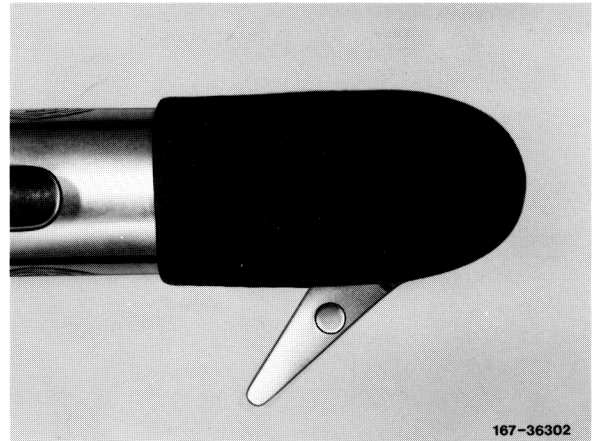

20 Move into operating position adjacent to front fender.

21 Switch on multi-cutter, plunge-cut knife at starting point "B" and cut through adhesive bead (pulling multi-cutter toward body).

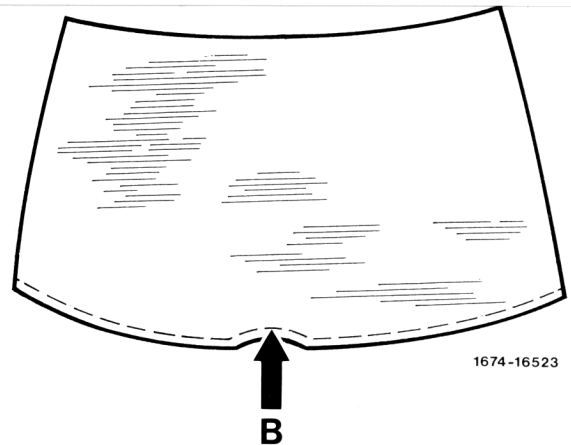

22 Switch off multi-cutter (interrupt air supply) and clamp knife in new position.

23 Change operating position and cut through bead on other side.

24 Switch off multi-cutter (interrupt air supply).

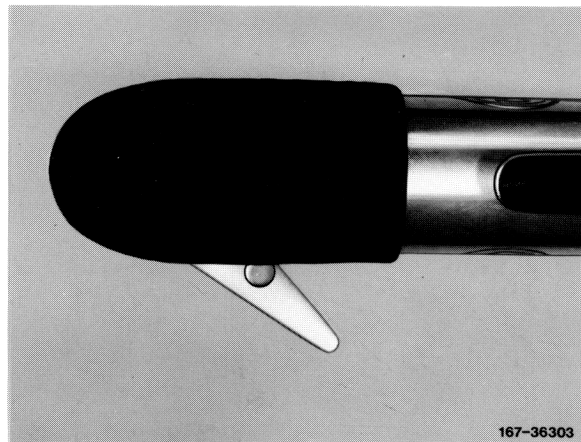

25 Change knife no. 2 for knife no. 3 and sharpen (item 13).

26 Lift glass in upper range of vehicle body and introduce knife from outside into gap.

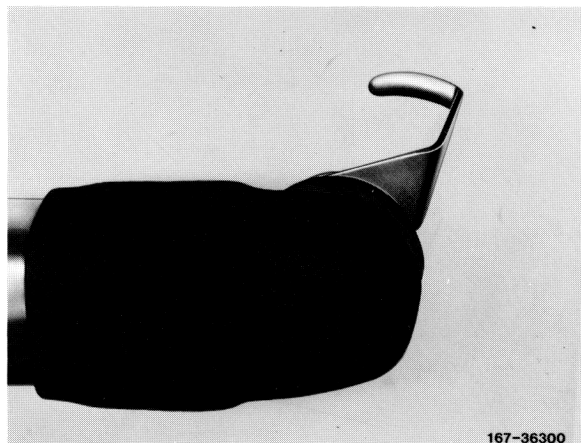

27 Switch on multi-cutter and cut from starting point "A" as far as the lower corners.

Note: If the adhesive material cannot be completely cut through with the available knives, use cutting wire.

28 When removing an undamaged glass pane, check prior to pushing pane out, whether there is enough free space all-around and remove holding clips for fastening water deflector by means of a chisel or the like, if required. Remove glass with suction lifter.

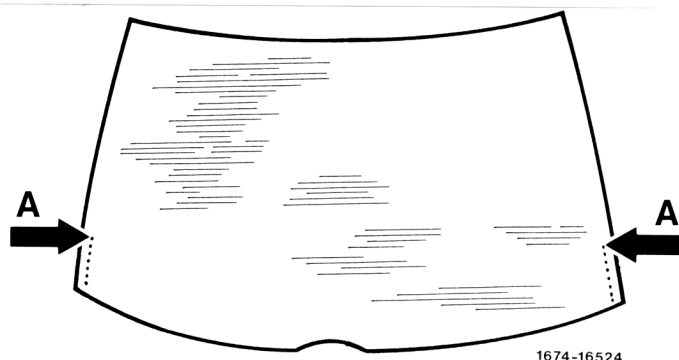

Installation

29 Change knife no. 3 for knife no. 2 (item 19), cut off remaining adhesive material on body flange. Max. 2 mm may remain in place. Pull off loose glueing material (not completely cut-off residual pieces).

Renew damaged holding strips, if required.

30 Coat paint damage on body flange, which is not covered by the glueing material, with priming pencil, part no. 000 986 06 50.

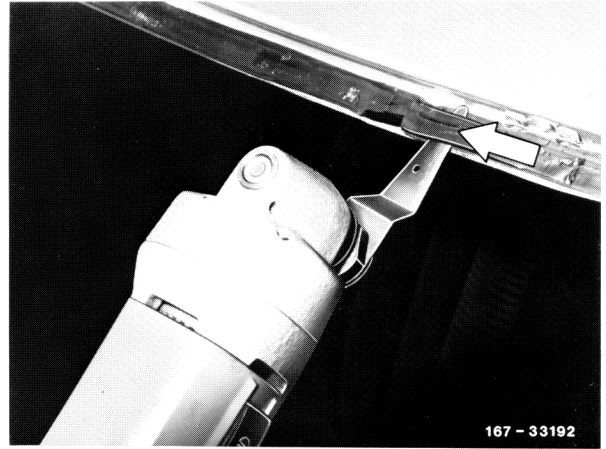

31 Prepare glass for glazing.

When using the previously installed glass pane:

Cut off residual glueing material on glass down to a few tenths of a millimeter. Renew damaged holding strips, if any.

Pull off loose glueing material (not completely cut-off residual parts) and rub off glueing range with non-fluffy rag.

Do not use cleaning compound.

Repair damaged primer layer.

Let primer air-dry for at least 5 minutes.

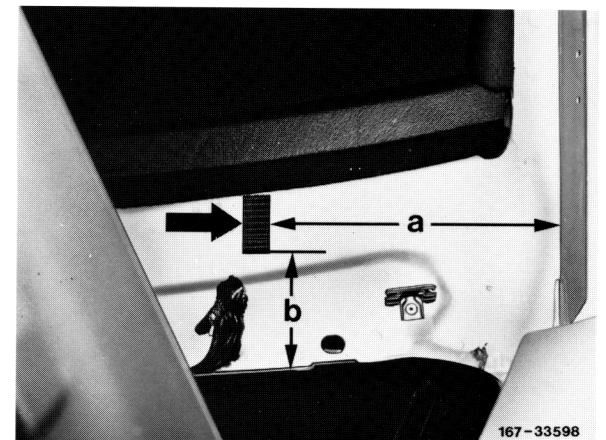
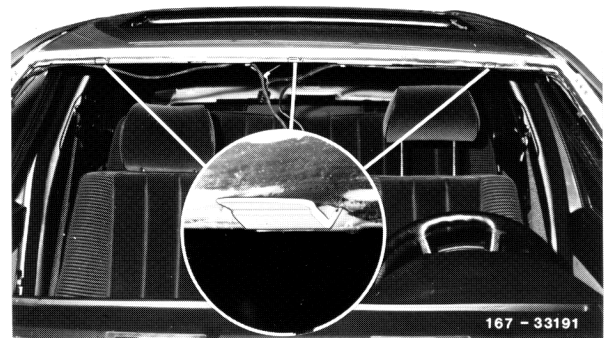

When installing a new glass pane:

Check pane for scratches and damage. Apply glass activator (cleaner) from repair pack with non-fluffy rag in glueing range, then rub dry with a second rag.

Attention!

Do not use cleaning compound in visibility range of glass, since this may lead to clouding.

Shake primer energetically and apply within glueing range (max. width 30 mm).

Let primer air-dry for at least 5 minutes.

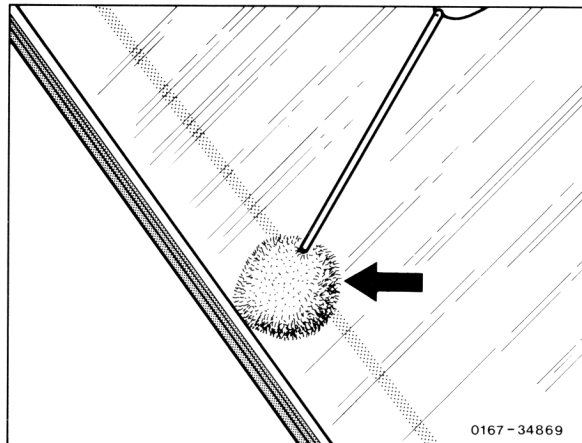

32 Push spacers (2 each) from repair pack into upper, outer holding clips.

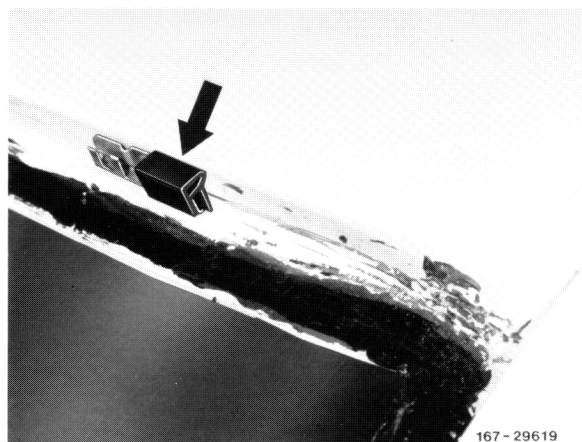

33 Insert angular spacers (3 each) from repair pack at top into body flange.

Check rubber buffers on lower glueing flange and renew, if required (contained in repair pack)

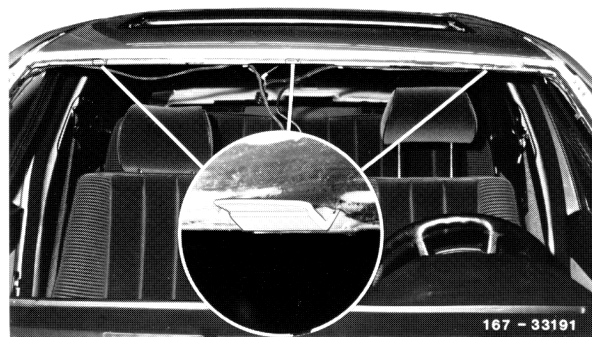

34 Preassemble glass pane support, below (item 6).

Note: When installing a new glass pane, glue holding strip (upper and lower part assembled) on cross member under windshield pane (arrow). Pull paper strip from upper part only after centering glass pane.

Dimension a = 120 mm
Dimension b = 60 mm



Assembly note

Prior to applying glue, center glass pane in body opening. For this purpose, mount suction lifter, position pane with second mechanic assisting at upper spacers and align. Glue on two adhesive tape strips, cut through at upper edge of pane and again remove pane.

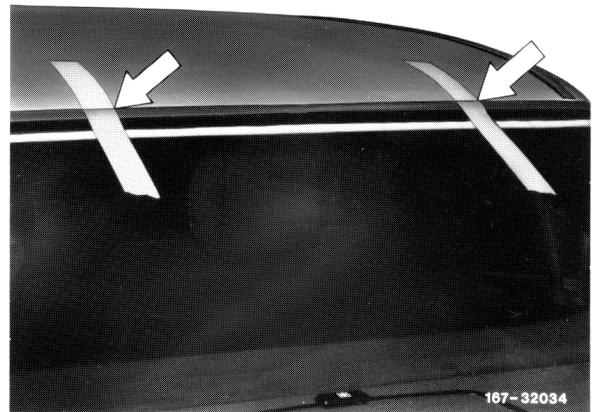

Note: When using the previously installed glass pane, mask holding strips on body with adhesive tape, so that the glass pane can be shifted for centering.

Pull off adhesive tape prior to inserting pane.

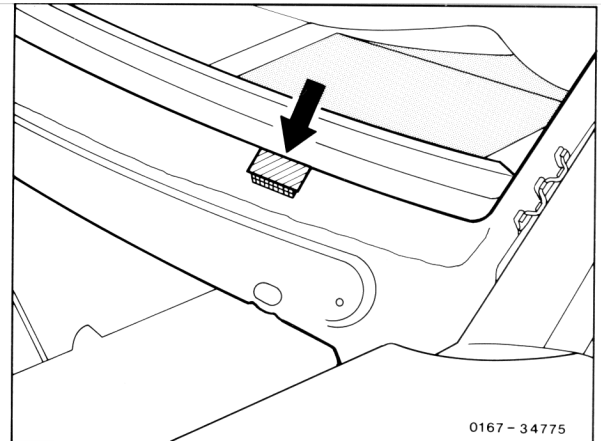

35 Remove cartridge with glue from repair pack. Cut through diaphragm, remove cartridge bottom and dump chemicals. Screw on application nozzle and insert cartridge in processing gun.

Guide nozzle along residual glue on body flange, while uniformly squeezing out the glueing material (height of glueing bead approx. 10 mm).



Attention!

Pane must be mounted within 15 minutes, since otherwise the adhesive characteristics of the glueing material will be impaired.

36 Open crank window on driver's door, so that the windshield pane cannot be pushed outward by the accumulating air while closing the doors during the drying period.

37 Position glass pane with a second mechanic assisting against upper spacers (adhesive tape flush), place on glueing bead and push down all-around as far as the spacer elements.

38 Slip glass pane support against bottom edge of glass and tighten or engage, respectively.

39 Remove spacers from clamps and clip-in trimstrip at top.

40 For further installation proceed vice versa.

Note: The drying time (stationary period of vehicle) amounts to approx. 4 hours. The rain test can be made upon completion of assembly jobs.

In the event of leaks, refer to 97-850.

B. Coupe

Special tools

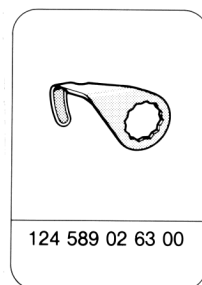
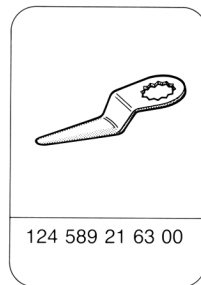
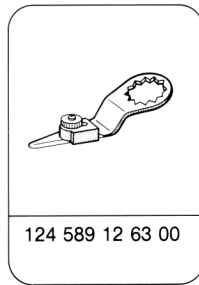

Conventional tools

e. g. company, Order no.

Multi-cutter

Chicago Pneumatic
D-65366 Geisenheim
CP 838-12

Suction lifter

Karl Assfalg KG, Buchstraße 149
D-73525 Schwäbisch Gmünd
602-2

Electric gun with battery

Weiler & Co.
Postfach 1269
D-76287 Rheinstetten, Baden
Pressofix 108, Electronic, SDF-108 E

Parts

Repair pack for glazing
windshield or back window glass

124 670 01 93

Scope

- 1 Coating brush
- 2 Glass primer
- 3 Glass activator (cleaner)
- 4 Betaseal glueing material 150 ml
- 5 Coating nozzles
- 6 Cutting wire, spacing blocks, spacing angle brackets, spacing rubber and cleaning cloth
- 7 Betaseal glueing material 300 ml

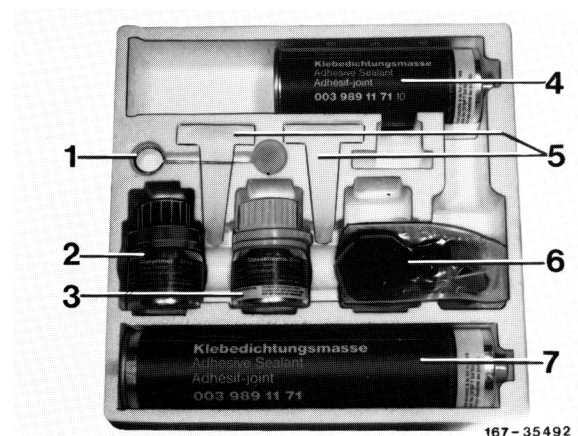

Removal

- 1 Open engine hood and position vertically.
- 2 Mask both front fenders in rear range with adhesive tape and additionally mount protective fender covers.
- 3 Remove wiper unit (Group 82).
- 4 Pull water deflectors at left and right out of holding clips and remove.
- 5 Push out top trimstrip by means of assembly wedge.
- 6 Pull off molded rubber strip.

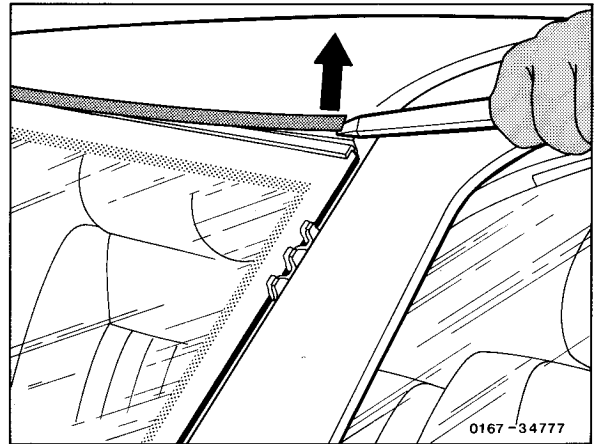

1st version

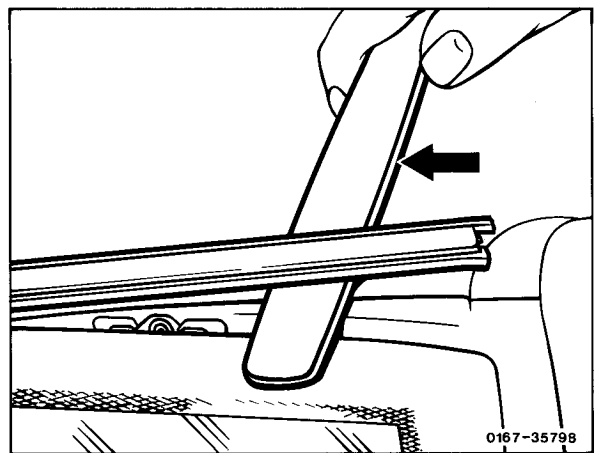

2nd version

7 With second mechanic, unscrew screws of engine hood left and right (do not separate electric connections and hoses on windshield washer nozzles).

8 Lift engine hood vertically above hinges and put down horizontally in front of hinges on protective fender covers.

9 On vehicles with trimstrip 2nd version, mark location of clips with felt pencil on pane and slightly pull back driving machine in clip range when cutting through glueing bead.

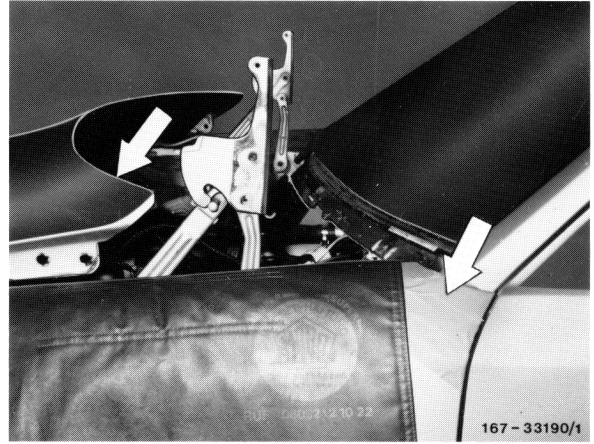

10 Remove reveal molding on windshield at top and laterally (68-400 and 68-405).

11 Locate multi-cutter available for use (air supply interrupted).

12 Clamp knife no. 1 into multi-cutter and set stop as required (dimension a = 18 mm).

13 Moisten oil stone, connect air supply and sharpen both sides of knife with machine switched on.

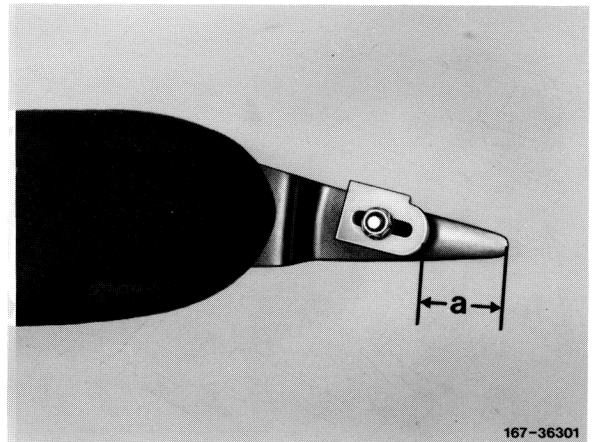

14 Switch off multi-cutter.

Attention!

Wear goggles.

15 Move into operating position (right-handers on front passenger seat, left-handers on driver's seat).

16 Switch on multi-cutter, plunge-cut with knife at starting point "A" and cut through adhesive bead, guiding knife in parallel with glass, in upward direction toward vehicle center.

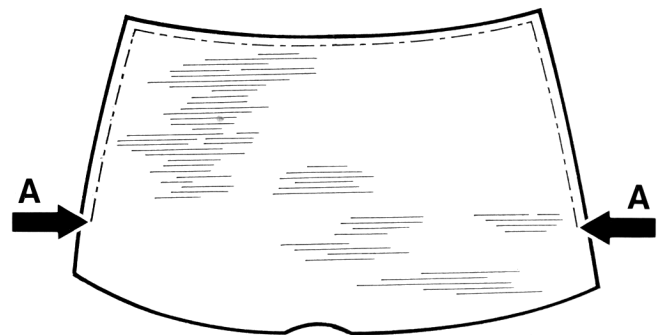

Note: Slightly pull back multi-cutter in range of upper clips (mark).

17 Switch off multi-cutter.

18 Change operating position and cut through bead on other side.

19 Switch off multi-cutter (interrupt air supply), change knife no. 1 for knife no. 2 and sharpen (item 13).

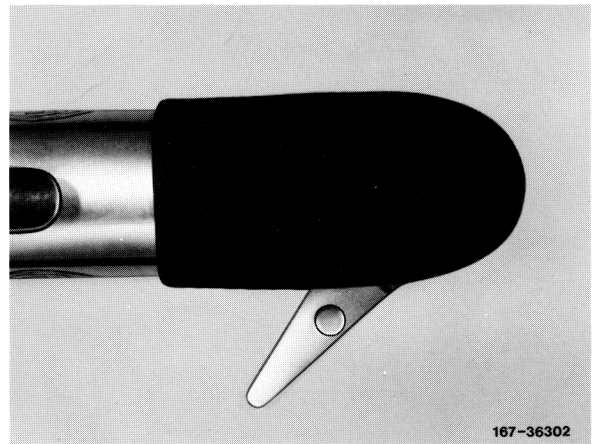

20 Move into operating position adjacent to front fender.

21 Switch on multi-cutter, plunge-cut knife at starting point "B" and cut through adhesive bead (pulling multi-cutter toward body).

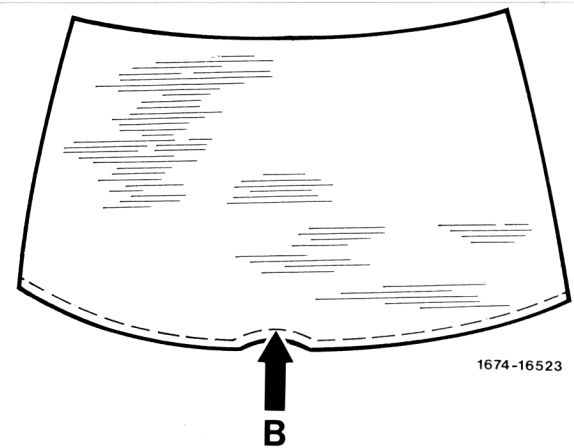

22 Switch off multi-cutter (interrupt air supply) and clamp knife in new position.

23 Change operating position and cut through bead on other side.

24 Switch off multi-cutter (interrupt air supply).

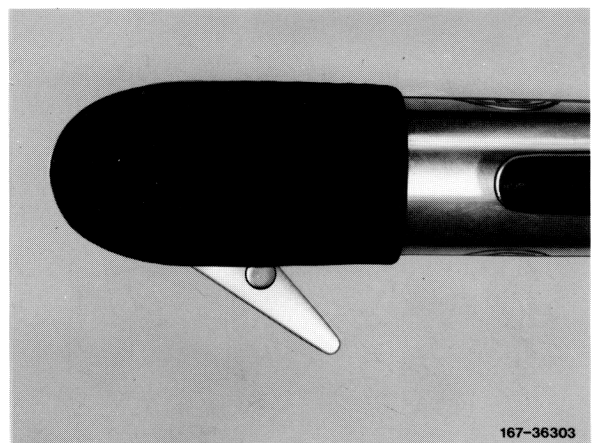

25 Change knife no. 2 for knife no. 3 and sharpen (item 15).

26 Lift glass in upper range of vehicle body and introduce knife from outside into gap.

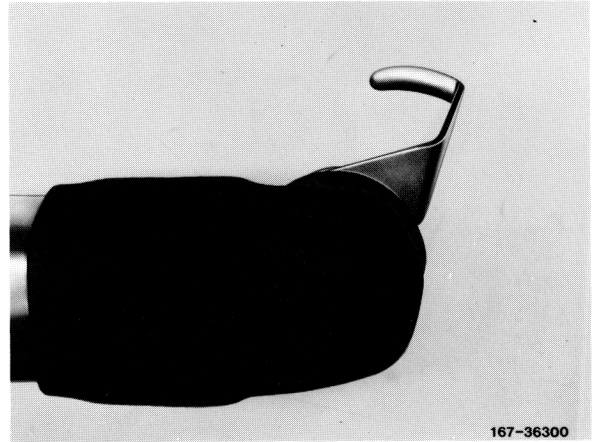

27 Switch on multi-cutter and cut from starting point "A" as far as the lower corners.

Note: If the adhesive material cannot be completely cut through with the available knives, use cutting wire.

28 When removing an undamaged glass pane, check prior to pushing pane out, whether there is enough free space all-around and remove holding clips for fastening water deflector, by means of a chisel or the like, if required. Remove glass with suction lifter.

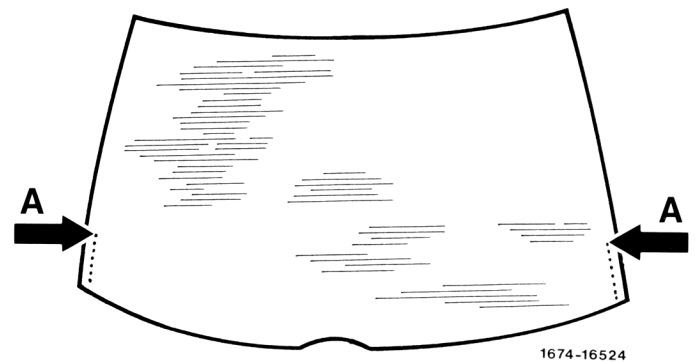

Installation

29 Change knife no. 3 for knife no. 2 (item 24), cut off remaining adhesive material on body flange. Max. 2 mm may remain in place. Pull off loose glueing material (not completely cut-off residual pieces). Renew damaged holding strips, if required.

30 Coat paint damage on body flange, which is not covered by the glueing material, with priming pencil, part no. 000 986 06 50.

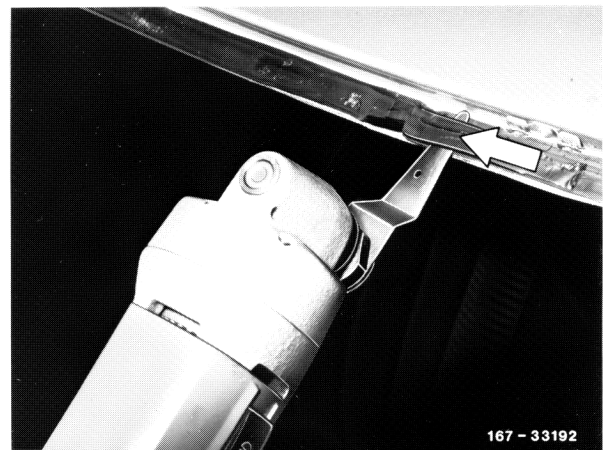

31 Prepare glass for glazing.

When using the previously installed glass pane:

Cut off residual glueing material on glass down to a few tenths of a millimeter. Renew damaged holding strips, if any.

Pull off loose glueing material (not completely cut-off residual parts) and rub off glueing range with non-fluffy rag.

Do not use cleaning compound.

Repair damaged primer layer.

Let primer air-dry for at least 5 minutes.

When installing a new glass pane:

Check pane for scratches and damage. Apply glass activator (cleaner) from repair pack with non-fluffy rag in glueing range, then rub dry with a second rag.

Attention!

Do not use cleaning compound in visibility range of glass, since this may lead to clouding.

Shake primer energetically and apply within glueing range (max. width 30 mm).

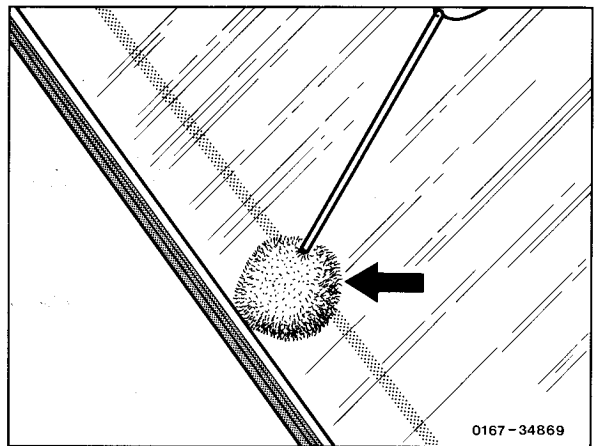

155/16

32 Premount trimstrip on glass pane.

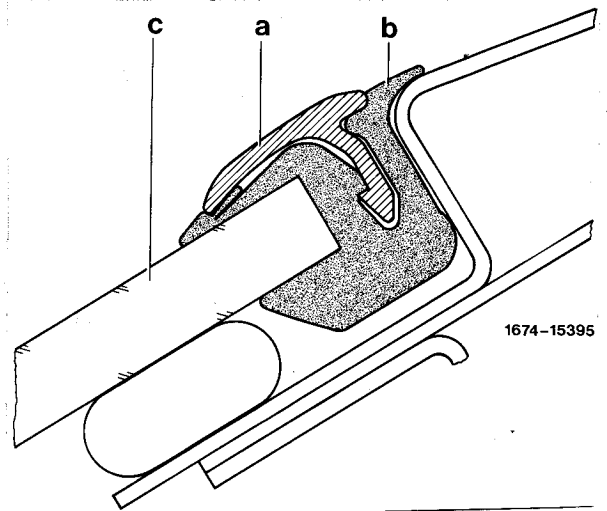

1st version

- a Trimstrip
- b Contoured rubber
- c Glass

33 Push spacers (2 each) from repair pack into upper, outer holding clips.

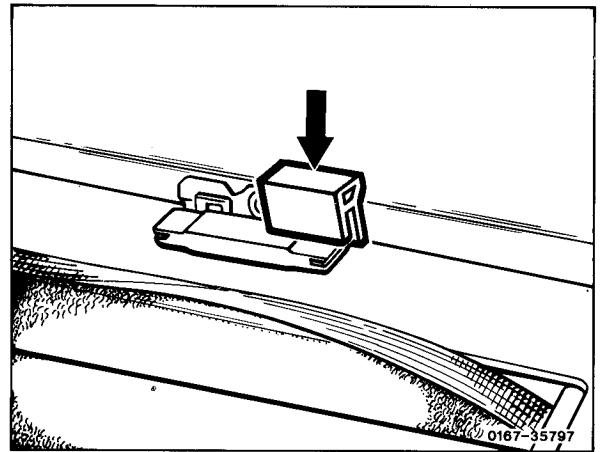

34 Insert angular spacers (3 each) from repair pack at top into body flange.

Note: When installing a new glass pane, glue holding strip (upper and lower part assembled) on cross member under windshield pane (arrow). Pull paper strip from upper part only after centering glass pane.

Dimension a = 90 mm
Dimension b = 60 mm

Assembly note

Prior to applying glue, center glass pane in body opening. For this purpose, mount suction lifter, position pane with second mechanic assisting at upper spacers and align (with trimstrip 1st version). Mark position of glass pane with a chalk stripe (arrow). Remove pane again.

1st version

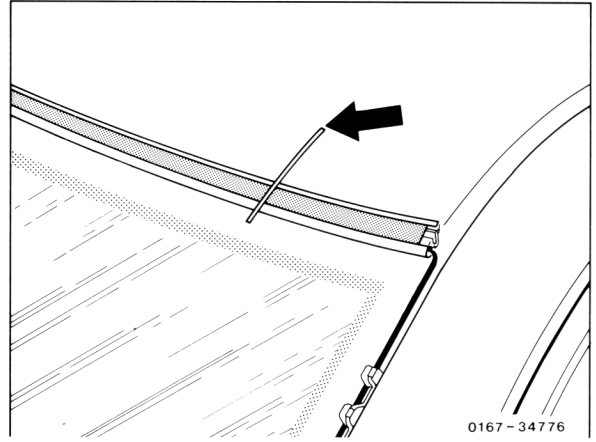

Place glass without trimstrip against upper spacers and align. Glue on two adhesive tape strips, cut through at upper edge of pane (arrow) and again remove pane.

2nd version

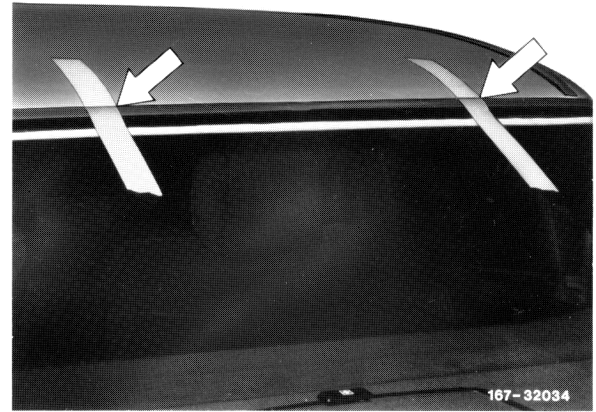

Note: When using the previously installed glass pane, mask holding strips on body with adhesive tape, so that the glass pane can be shifted for centering.

Pull off adhesive tape prior to inserting pane.

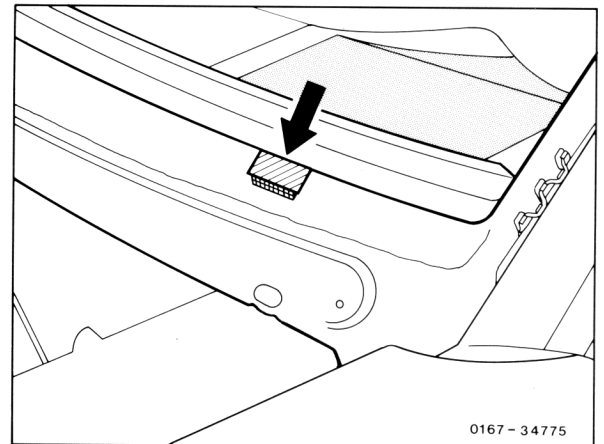

35 Remove cartridge with glue from repair pack. Cut through diaphragm, remove cartridge bottom and dump chemicals. Screw on application nozzle and insert cartridge in processing gun.

Guide nozzle along residual glue on body flange, while uniformly squeezing out the glueing material (height of glueing bead approx. 10 mm).



Attention!

Pane must be mounted within 15 minutes, since otherwise the adhesive characteristics of the glueing material will be impaired.

36 Open crank window on driver's door, so that the windshield pane cannot be pushed outwards by the accumulating air while closing the door during the drying period.

37 Position glass pane (with trimstrip 1st version), with a second mechanic assisting, against upper chalk marks, align, place on glueing bead, press down all-around until the rubber profile at top is resting perfectly against body and the holding strips at bottom are glued to pane or engaged.

38 Position pane (without trimstrip 2nd version) against upper spacers (with adhesive tape strip flush), place on glueing bead and push in all-around against the spacer elements.

39 For further installation proceed vice versa.

Note: The drying time (stationary period of vehicle) amounts to approx. 4 hours. The rain test can be made upon completion of assembly jobs.

In the event of leaks, refer to 97-850.

C. Convertible

Preliminary work:

Removal and installation of reveal molding at side of windshield (68-405).

Removal and installation of panel above windshield (68-410).

Removal and installation of reveal molding at top of windshield (68-425).

Engine hood in vertical position

Removal and installation of windshield wiper system (82-680).

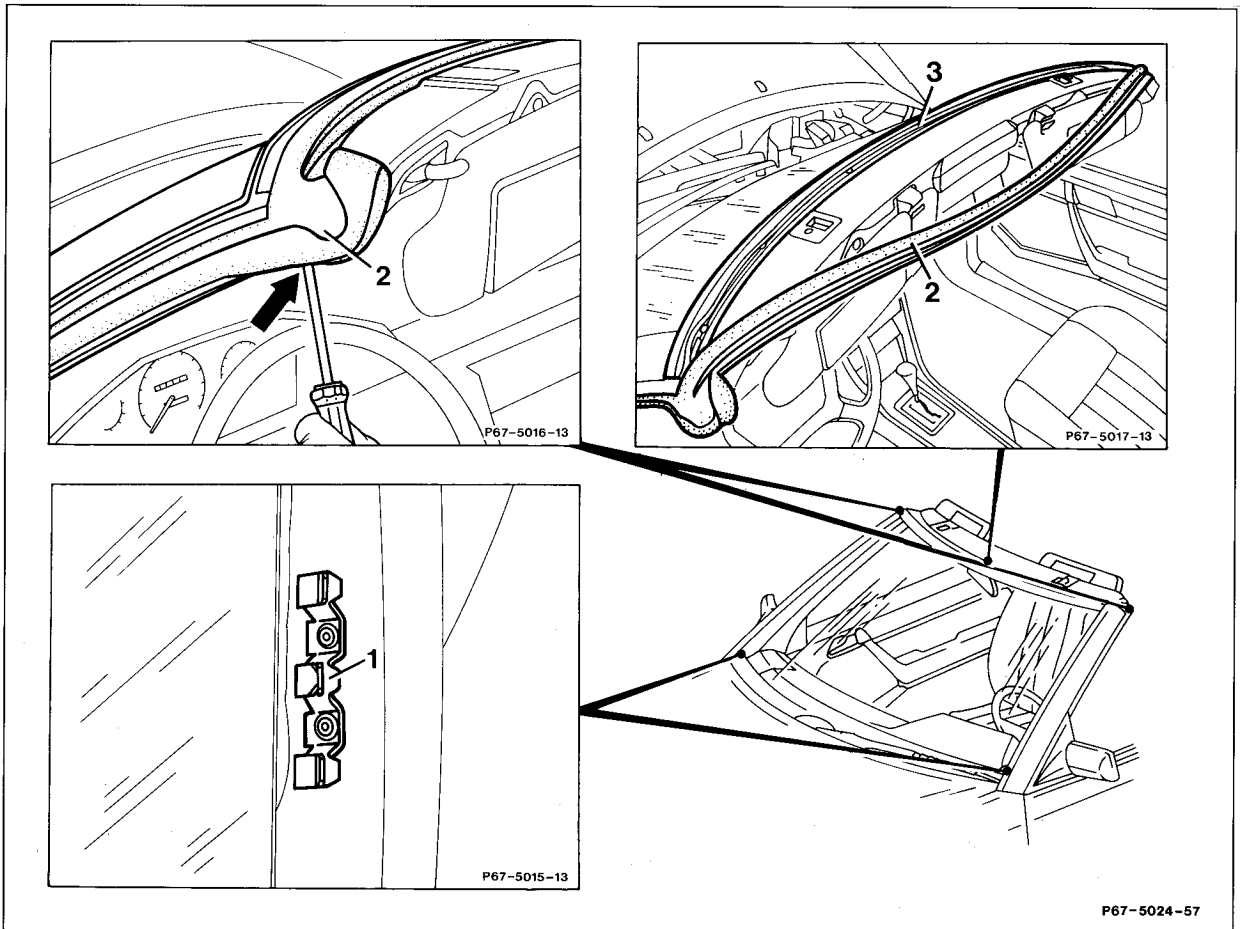

Fenders in area of A-pillar	mask with masking tape and cover fenders with protective fender covers.
Molding on A-pillar	remove, install.
Clip (1)	remove, install (chisel off rivet head, rivet on).
Screw (arrow)	screw out of sealing frame (2), screw in.
Sealing frame (2)	pull off, install (item 11).
Molding (3)	remove, install.

Note

Replace damaged seals.

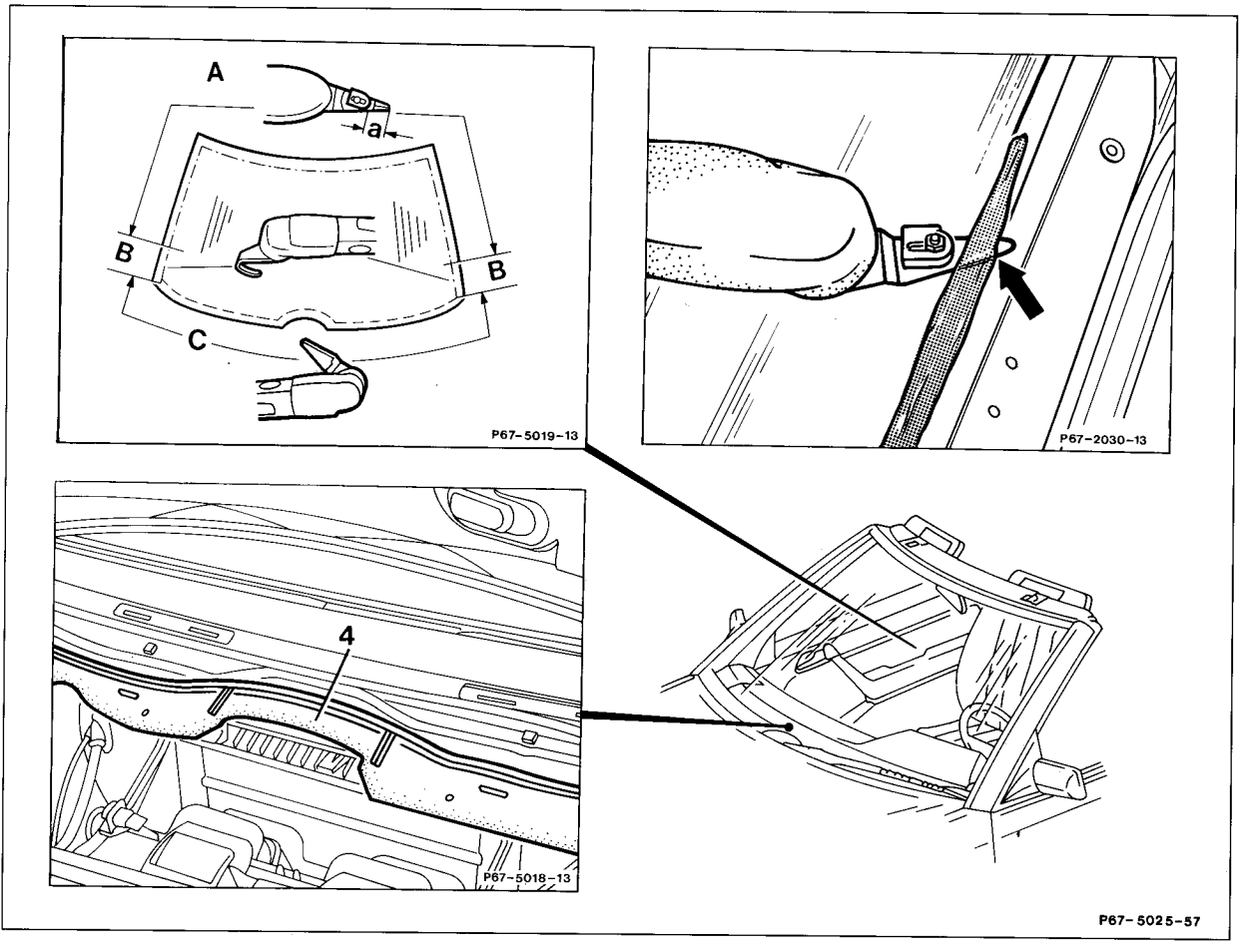

Seal (4) below windshield (only on vehicles with air conditioner)

Blade 124 589 12 63 00

pull out, install.

clamp into multi-cutter.



Ensure that the air supply is interrupted when clamping in the blade. Wear goggles when cutting out the windshield.

Blade

Windshield in area «A»

Blade 124 589 21 63 00

Blade

Windshield in area «C»

Blade 124 589 02 63 00

Blade

Windshield in area «B»

Windshield

sharpen (item 1).

cut out (item 2).

clamp into multi-cutter.

sharpen (item 1).

cut out (item 2).

clamp into multi-cutter.

sharpen (item 1).

cut out.

remove (item 3).

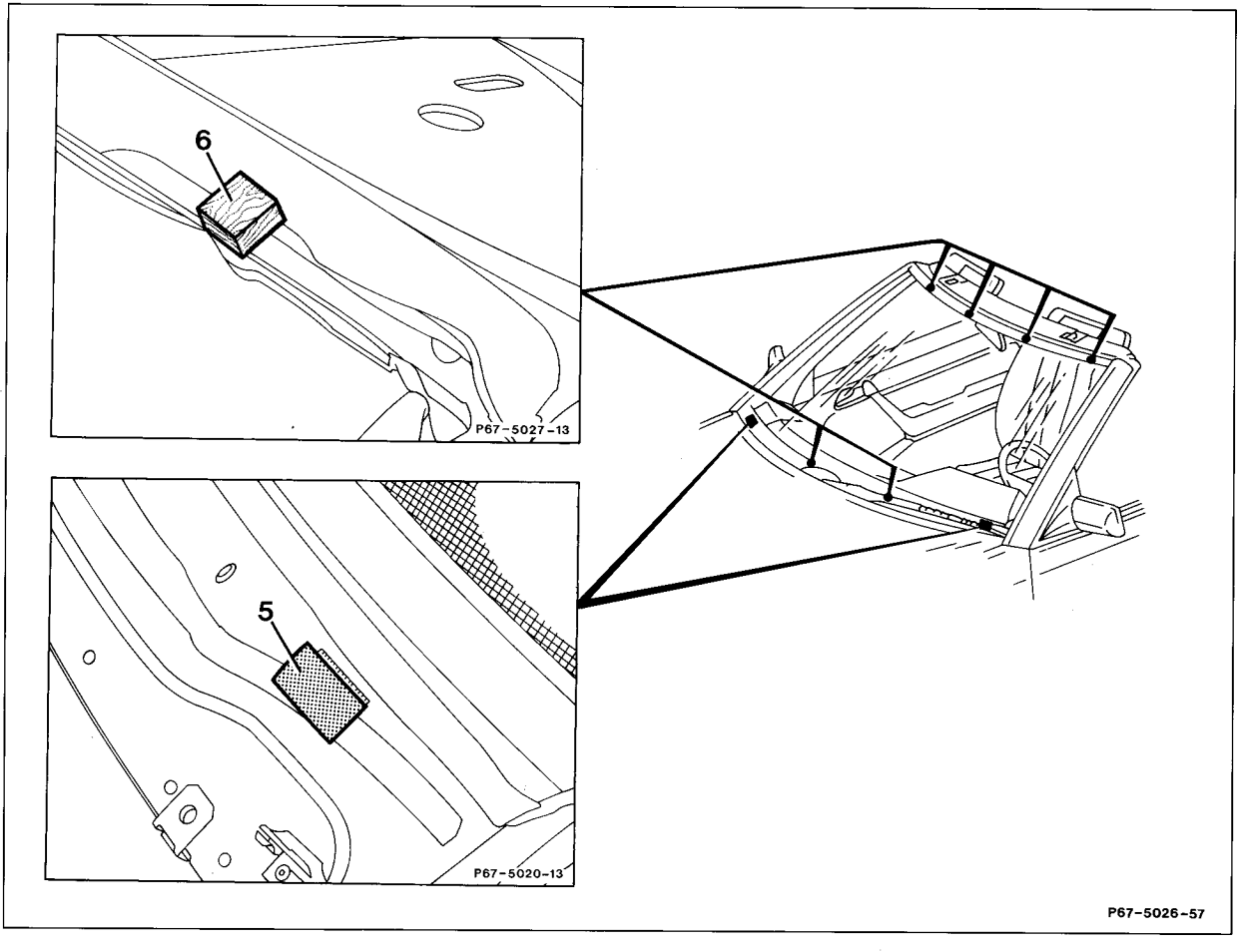

Retaining strips (5) and rubber spacers (6)
 Windshield
 Windshield
 Protective foil
 Glue

replace.
 prepare for glazing (items 4 through 6).
 align (items 7 through 8).
 remove from retaining strips (5).
 apply (items 9 through 11)



Windshield must be mounted within 15 minutes, since otherwise the adhesive characteristics of the glueing material will be impaired.

Windshield

install (item 12).

Note

The drying time (stationary period of vehicle) amounts to approx. 4 hours. The rain test can be made upon completion of assembly work.

In the event of leaks, refer to 97-850.

1.00.25

Special tools

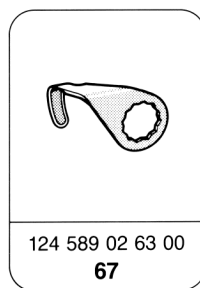
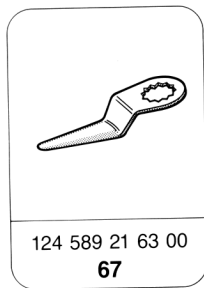
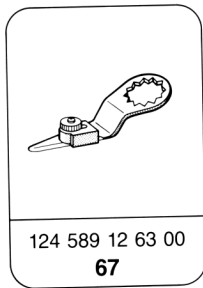

Commercially available tools	order no	e.g. Company,
Multi-cutter	CP 838 - 12	Chicago Pneumatic D-65366 Geisenheim
Suction lifter	602 - 2	Karl Assfalg KG, Buchstraße 149 D-73525 Schwäbisch Gmünd
Electric gun with battery.	Pressofix 108 Electronic SDF - 108 E	Weiler & Co. Postfach 12 69 D-76287 Rheinstetten, Baden

Parts

Repair pack for glazing windshield or back window glass	124 670 01 93
---	---------------

Scope of delivery

- 1 Coating brush
- 2 Glass primer
- 3 Glass activator (cleaner)
- 4 Betaseal glueing material 150 ml
- 5 Coating nozzles
- 6 Cutting wire, spacing blocks, spacing angles, rubber spacers and cleaning cloth
- 7 Betaseal glueing material 300 ml



1 Moisten whet stone and sharpen both sides of blade with machine switched on.

2 Cut out windshield at side in area "A" (stop a = 28 mm) from inside and at top from outside.

Cut out in area "C" from outside.

Cut out in area "B" from outside.

Note

If the adhesive material cannot be cut through completely with the blades available, use cutting wire.

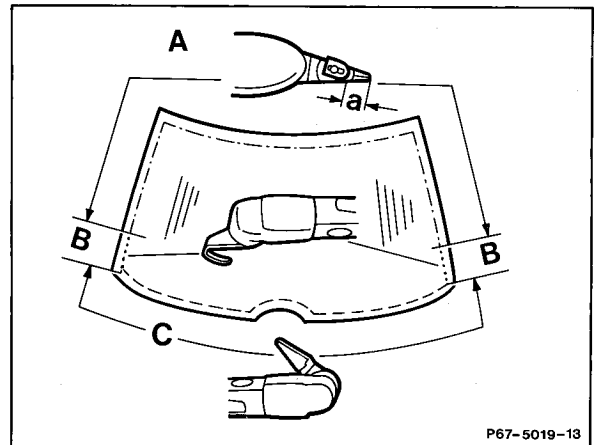

3 Remove windshield from body with suction lifter and cut remaining adhesive material off of body flange.

Note

Max. 2 mm may remain in place. Pull off loose glueing material (not completely cut-off residual pieces).

Coat paint damage on body flange, which is not covered by the glueing material, with priming pencil, part no. 000 986 06 50.

4 When using previously installed windshield: Cut off residual glueing material on glass down to a few tenths of a millimeter. Pull off loose glueing material (not completely cut-off residual parts) and rub off glueing range with non-fluffy rag. Do not use cleaning compound. Repair damaged primer layer.

Let primer air-dry for at least 5 minutes.

5 When installing a new windshield:
Check windshield for scratches and damage.
Apply glass activator (cleaner) from repair pack
with non-fluffy rag in glueing range, then rub dry
with a second rag.



Do not use cleaning compound in visibility range
of glass, since this may lead to clouding.

6 Shake primer energetically and apply within
glueing range (max. width 30 mm).
Let primer air-dry for at least 5 minutes.

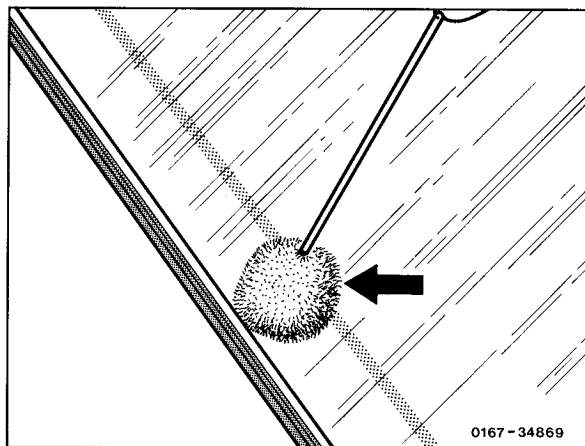

7 Before applying glue center windshield in
body opening, dimension A = 34 mm, measured
from top of retaining clip to top of windshield.

8 Apply strips of adhesive tape, cut through at
top of windshield and remove windshield again.

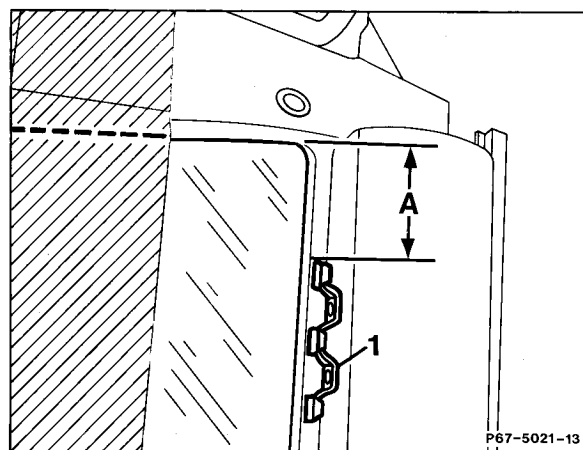

9 Remove cartridge with glue from repair pack.
Cut through diaphragm, remove cartridge
bottom. Screw on application nozzle and insert
cartridge in processing gun.

Guide nozzle along residual glue on body flange,
while uniformly squeezing out the glueing
material (height of glueing bead approx. 10 mm).

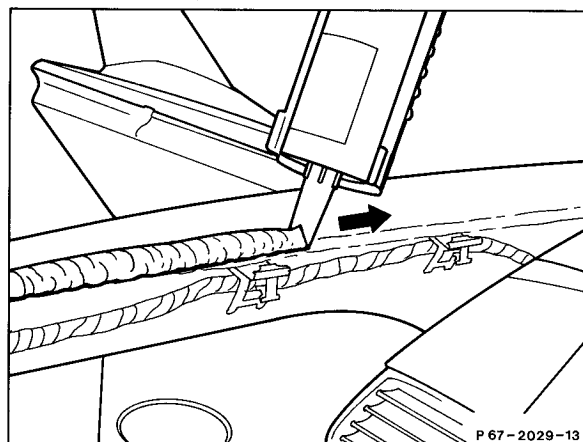

11056

10 Lift seal (4) at side and apply bead of glue.

11 Press seal (4) into bead of glue (only on vehicles with air conditioner).



Windshield must be mounted within 15 minutes, since otherwise the adhesive characteristics of the glueing material will be impaired.

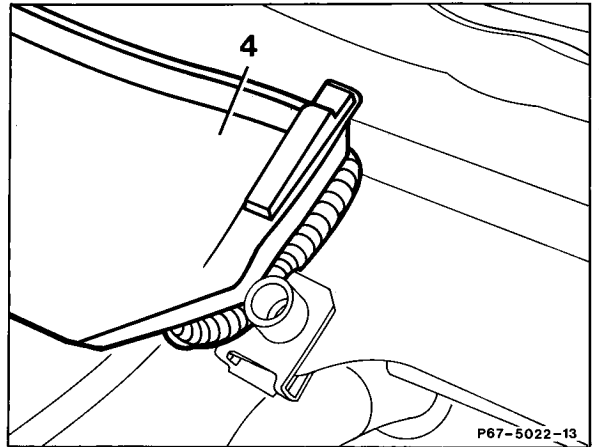

12 Position windshield with help of second mechanic on adhesive bead with strips of adhesive tape aligned and press down until it contacts the retaining strips (5) at the bottom and the rubber spacers (6) at the top.

13 Install sealing frame (2) in retaining strip on A-pillar.



When pressing in ensure that the hook (arrow) on the retaining rail engages in the pocket (arrow) on the sealing frame (2).

Note

The drying time (stationary period of vehicle) amounts to approx. 4 hours. The rain test can be made upon completion of assembly jobs.

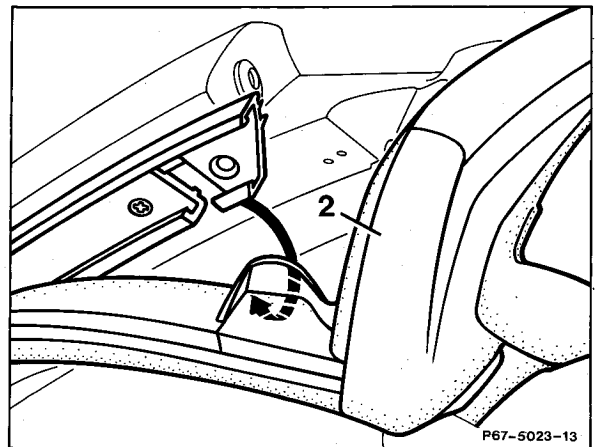

In the event of leaks, refer to 97-850.

Continue assembly in opposite order.

10026